



Multi-turn actuators

SAVEx 07.2 – SAVEx16.2

SARVEx 07.2 – SARVEx16.2

Control unit: electronic (MWG)
with actuator controls

ACVExC 01.2 Non-Intrusive

Control

Parallel

→ Profibus DP

Modbus RTU

Modbus TCP/IP

Foundation Fieldbus

HART



Read operation instructions first.

- Observe safety instructions.
- These operation instructions are part of the product.
- Store operation instructions during product life.
- Pass on instructions to any subsequent user or owner of the product.

Target group:

This document contains information for assembly, commissioning and maintenance staff.

Reference documents:

- Manual (Operation and setting) of actuator controls ACVExC 01.2 Profibus DP
- Manual (Fieldbus device integration) of actuator controls ACVExC 01.2 Profibus DP

Reference documents are available on the Internet at: <http://www.auma.com>.

Table of contents

Page

1.	Safety instructions.....	5
1.1.	Prerequisites for the safe handling of the product	5
1.2.	Range of application	6
1.3.	Warnings and notes	7
1.4.	References and symbols	7
2.	Short description.....	8
3.	Name plate.....	10
4.	Transport, storage and packaging.....	14
4.1.	Transport	14
4.2.	Storage	15
5.	Assembly.....	17
5.1.	Mounting position	17
5.2.	Handwheel fitting	17
5.3.	Mount actuator to valve	17
5.3.1.	Overview of output drive types	18
5.3.2.	Output drive type A	18
5.3.2.1.	Multi-turn actuator with output drive type A: mount	19
5.3.2.2.	Stem nut for output drive type A: finish machining	21
5.3.3.	Output drive types B/C/D and E	22
5.3.3.1.	Multi-turn actuator with output drive type B: mount	23
5.4.	Accessories for assembly	24
5.4.1.	Stem protection tube for rising valve stem	24
5.5.	Mounting positions of local controls	25
5.5.1.	Mounting positions: modify	25
6.	Electrical connection.....	26
6.1.	Basic information	26
6.2.	Overview of AUUMA electrical connections	29
6.3.	KT/KM electrical connection	30
6.3.1.	Terminal compartment: open	31
6.3.2.	Cable connection	32
6.3.3.	Fieldbus cables: connect	34

6.3.3.1.	Fieldbus connection for line topology	34
6.3.4.	Terminal compartment: close	36
6.4.	KP/KPH electrical connection	37
6.4.1.	Terminal compartment: open	38
6.4.2.	Cable connection	39
6.4.3.	Fieldbus cables: connect	40
6.4.4.	Terminal compartment: close	41
6.5.	KES electrical connection	42
6.5.1.	Terminal compartment: open	43
6.5.2.	Cable connection	44
6.5.3.	Fieldbus cables: connect	45
6.5.4.	Terminal compartment: close	46
6.6.	External earth connection	46
6.7.	Accessories for electrical connection	47
6.7.1.	Actuator controls on wall bracket	47
6.7.2.	Parking frame	48
7.	Operation.....	49
7.1.	Manual operation	49
7.1.1.	Manual valve operation	49
7.2.	Motor operation	50
7.2.1.	Operating the actuator from local controls	50
7.2.2.	Actuator operation from remote	51
7.3.	Menu navigation via push buttons (for settings and indications)	51
7.3.1.	Menu layout and navigation	52
7.4.	User level, password	53
7.4.1.	Password entry	54
7.4.2.	Password change	54
7.4.3.	Timeout for incorrect password entry	55
7.5.	Language in the display	55
7.5.1.	Language change	55
8.	Indications.....	57
8.1.	Indications during commissioning	57
8.2.	Indications in the display	57
8.2.1.	Feedback signals from actuator and valve	58
8.2.2.	Status indications according to AUMA classification	60
8.2.3.	Status indications according to NAMUR recommendation	61
8.3.	Indication lights of local controls	63
8.4.	Optional indications	64
8.4.1.	Mechanical position indication via indicator mark (not self-adjusting)	64
8.4.2.	Mechanical position indication (self-adjusting)	64
9.	Signals (output signals).....	65
9.1.	Signals via fieldbus	65
9.2.	Status signals via output contacts (digital outputs)	65
9.2.1.	Assignment of outputs	65
9.2.2.	Coding the outputs	65
9.3.	Analogue signals (analogue outputs)	66
10.	Commissioning (basic settings).....	67
10.1.	Type of seating: set	67
10.2.	Torque switching: set	68

10.3.	Limit switching: set	70
10.4.	Output speed (internal): set	72
10.5.	Fieldbus address (slave address): set	73
10.6.	Test run	74
10.6.1.	Direction of rotation at mechanical position indicator: check	74
10.6.2.	Direction of rotation at hollow shaft/stem: check	76
10.6.3.	Limit switching: check	76
11.	Commissioning (settings/options in the actuator).....	78
11.1.	Switch compartment: open/close	78
11.2.	Mechanical position indicator (self-adjusting)	79
11.2.1.	Mechanical position indicator: set	79
11.2.2.	Gear stage of the reduction gearing: test/set	80
11.3.	Mechanical position indication via indicator mark (not self-adjusting)	81
11.3.1.	Mechanical position indicator: set	81
11.3.2.	Gear stage of the reduction gearing: test/set	82
12.	Corrective action.....	85
12.1.	Faults during commissioning	85
12.2.	Fault indications and warning indications	85
12.2.1.	Signal for temperature warning of PTC tripping device	89
12.3.	Fuses	89
12.3.1.	Fuses within the actuator controls	89
12.3.2.	Motor protection (thermal monitoring)	89
13.	Servicing and maintenance.....	91
13.1.	Preventive measures for servicing and safe operation	91
13.2.	Disconnection from the mains	92
13.2.1.	Disconnection from the mains with KT/KM electrical connection	92
13.2.2.	Disconnection from the mains with KP/KPH and KES electrical connection	93
13.3.	Maintenance	94
13.4.	Disposal and recycling	95
14.	Technical data.....	96
14.1.	Technical data Multi-turn actuators	96
14.2.	Technical data Actuator controls	98
14.3.	Tightening torques for screws	103
15.	Spare parts.....	104
15.1.	Multi-turn actuators SAVEx 07.2 – SAVEx 16.2/SARVEx 07.2 – SARVEx 16.2 KT/KM	104
15.2.	ACVExC 01.2 KT/KM actuator controls	106
15.3.	ACVExC 01.2 KP/KPH actuator controls	108
15.4.	ACVExC 01.2 KES actuator controls	110
	Index.....	112

1. Safety instructions

1.1. Prerequisites for the safe handling of the product

- Standards/directives** The end user or the contractor must ensure that all legal requirements, directives, guidelines, national regulations and recommendations with respect to assembly, electrical connection, commissioning and operation are met at the place of installation. They include among others:
- Standards and directives such as IEC 60079 “Explosive atmospheres”:
 - Part 14: Electrical installations design, selection and erection.
 - Part 17: Electrical installations inspection and maintenance.
 - Applicable configuration guidelines for fieldbus applications.
- Safety instructions/warnings** All personnel working with this device must be familiar with the safety and warning instructions in this manual and observe the instructions given. Safety instructions and warning signs on the device must be observed to avoid personal injury or property damage.
- Qualification of staff** Assembly, electrical connection, commissioning, operation, and maintenance must be carried out by suitably qualified personnel authorised by the end user or contractor of the plant only.
- Prior to working on this product, the staff must have thoroughly read and understood these instructions and, furthermore, know and observe officially recognised rules regarding occupational health and safety.
- Work performed in potentially explosive atmospheres is subject to special regulations which have to be observed. The end user or contractor of the plant is responsible for respect and control of these regulations, standards, and laws.
- Electrostatic charging** Highly efficient charge generating processes (processes more efficient than manual friction) on the device surface must be excluded at any time, since they will lead to propagating brush discharges and therefore to ignition of a potentially explosive atmosphere.
- This also applies to fireproof coatings or covers available as an option.
- Ignition dangers** Gearboxes were subjected to an ignition hazard assessment in compliance with the currently applicable standard according to ISO 80079-36/ -37. Hot surfaces, mechanically generated sparks as well as static electricity and stray electric currents were identified and assessed as major potential ignition sources. Protective measures to prevent the likelihood that ignition sources arise were applied to the gearboxes. This includes in particular lubrication of the gearbox, the IP protection codes and the warnings and notes contained in these operation instructions.
- Commissioning** Prior to commissioning, imperatively check that all settings meet the requirements of the application. Incorrect settings might present a danger to the application, e.g. cause damage to the valve or the installation. The manufacturer will not be held liable for any consequential damage. Such risk lies entirely with the user.
- Operation** Prerequisites for safe and smooth operation:
- Correct transport, proper storage, mounting and installation, as well as careful commissioning.
 - Only operate the device if it is in perfect condition while observing these instructions.
 - Immediately report any faults and damage and allow for corrective measures.
 - Observe recognised rules for occupational health and safety.
 - Observe national regulations.
 - During operation, the housing warms up and surface temperatures > 60 °C may occur. To prevent possible burns, we recommend checking the surface temperature prior to working on the device using an appropriate thermometer and wearing protective gloves.

Protective measures	The end user or the contractor are responsible for implementing required protective measures on site, such as enclosures, barriers, or personal protective equipment for the staff.
Maintenance	To ensure safe device operation, the maintenance instructions included in this manual must be observed. Any device modification requires prior written consent of the manufacturer.

1.2. Range of application

AUMA multi-turn actuators SAVEx 07.2 – SAVEx 16.2/SARVEx 07.2 – SARVEx 16.2 are designed for the operation of industrial valves, e.g. globe valves, gate valves, butterfly valves, and ball valves.

The devices described below are approved for use in the potentially explosive atmospheres of zones 1, 2, 21, and 22.

If temperatures >40 °C are to be expected at the valve flange or the valve stem (e.g. due to hot media), please consult AUMA. Temperatures > 40 °C are not considered with regard to the non-electrical explosion protection.

Other applications require explicit (written) confirmation by the manufacturer.

The following applications are not permitted, e.g.:

- Industrial trucks according to EN ISO 3691
- Lifting appliances according to EN 14502
- Passenger lifts according to DIN 15306 and 15309
- Service lifts according to EN 81-1/A1
- Escalators
- Continuous duty
- Buried service
- Continuous underwater use (observe enclosure protection)
- Potentially explosive areas of zones 0 and 20
- Potentially explosive areas of group I (mining)
- Radiation exposed areas in nuclear power plants

No liability can be assumed for inappropriate or unintended use.

Observance of these operation instructions is considered as part of the device's designated use.

These operation instructions are only valid for the “clockwise closing” standard version, i.e. driven shaft turns clockwise to close the valve. For “counterclockwise closing” version, a supplement must be observed in addition to these operation instructions.

Specific conditions of use

The particular conditions of use are listed on the certificates supplied. Among others, this includes the following conditions:

- Refer to [page 5, Electrostatic charging](#) for further references to minimise the risk of electrostatic charging within a potentially explosive atmosphere.
- For information regarding the dimensions of the flameproof joints, contact the manufacturer.
- Special fasteners according to IEC 60079-0 to seal flameproof enclosures must at least have a strength class of A*-70.
- For fixing the screws, please also refer to [page 103, Tightening torques for screws](#).
- After tripping of the thermal motor protection (TMS), an acknowledgement (RESET) of the thermal fault is required.

1.3. Warnings and notes

The following warnings draw special attention to safety-relevant procedures in these operation instructions, each marked by the appropriate signal word (DANGER, WARNING, CAUTION, NOTICE).



Indicates an imminently hazardous situation with a high level of risk. Failure to observe this warning results in death or serious injury.



Indicates a potentially hazardous situation with a medium level of risk. Failure to observe this warning could result in death or serious injury.



Indicates a potentially hazardous situation with a low level of risk. Failure to observe this warning could result in minor or moderate injury. May also be used with property damage.



Potentially hazardous situation. Failure to observe this warning could result in property damage. Is not used for personal injury.

Safety alert symbol  warns of a potential personal injury hazard.
 The signal word (here: DANGER) indicates the level of hazard.

1.4. References and symbols

The following references and symbols are used in these instructions:

Information

The term **Information** preceding the text indicates important notes and information.



Symbol for CLOSED (valve closed)



Symbol for OPEN (valve open)



Via the menu to parameter

Describes the menu path to the parameter. When using the push buttons of local controls, the required parameter can be quickly found on the display. Display texts are shaded in grey: **Display**.



Result of a process step

Describes the result of a preceding process step.

Warning signs at the device

The following warning signs can be attached to the device.



General warning sign

General warning of a danger zone.



Hot surface

Warning of hot surfaces, e.g. possibly caused by high ambient temperatures or strong direct sunlight.



Electrical voltage

Hazardous voltage! Warning of electric shock. At some devices, the warning sign additionally includes a time interval, e.g. 30 s. Once power supply is switched off, you will have to wait for the indicated period. Only then may the device be opened.

2. Short description

Multi-turn actuator Definition in compliance with EN 15714-2/EN ISO 5210:

A multi-turn actuator is an actuator which transmits torque to a valve for at least one full revolution.

AUMA multi-turn actuator Figure 1: AUMA SAVEx 10.2 multi-turn actuator

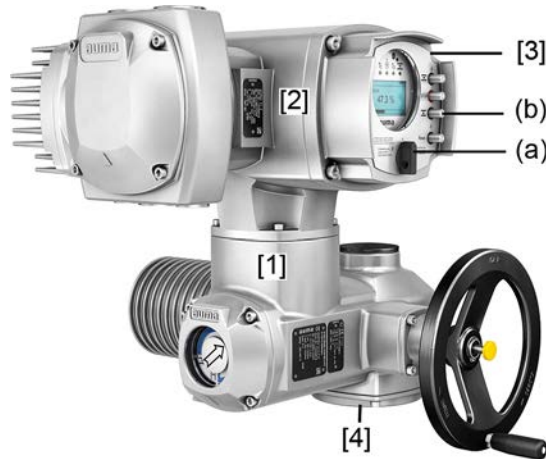

- [1] Multi-turn actuator with motor and handwheel
- [2] Actuator controls
- [3] Local controls with display, (a) selector switch and (b) push button
- [4] Valve connection, e.g. output drive type A

AUMA multi-turn actuators SAVEx 07.2 – SAVEx 16.2/SARVEx 07.2 – SARVEx 16.2 are driven by an electric motor. A handwheel is available for setting and emergency operation.

Switching off in end positions may be either by limit or torque seating.

Actuator controls are required to operate or process the actuator signals.

For non-intrusive version (control unit: electromechanical version), limit and torque setting is made via switches within the actuator.

For non-intrusive version (control unit: electronic version), limit and torque setting is made via the actuator controls, neither actuator nor the actuator controls housing have to be opened. For this purpose, the actuator is equipped with an MWG (magnetic limit and torque transmitter), also capable of supplying analogue torque feedback signals/torque indication and analogue position feedback signals/position indication at the actuator controls output.

In combination with output drive type A, the actuator is capable of withstanding thrust.

For variable speed multi-turn actuators SAVEx 07.2 – SAVEx 16.2/SARVEx 07.2 – SARVEx 16.2, the actuator speed is modified by means of a frequency converter in the actuator controls.

Actuator controls The actuator controls ACVExC 01.2 may be mounted directly to the actuator or separately on a wall bracket.

The actuator can be operated via the push buttons on the local controls of the actuator controls or settings can be made in the actuator controls menu. The display shows information on the actuator as well as the menu settings.

The functions of the actuator controls include standard valve control in OPEN-CLOSE duty, positioning, process control, logging of operating data, diagnostic functions right through control via various interfaces (e.g. fieldbus, Ethernet and HART).

App and software

Using the **AUMA CDT** software for Windows-based computers (notebooks or tablets) and the **AUMA Assistant App**, actuator data can be uploaded and read, settings can be modified and stored. The connection between computer and AUMA actuator

is established wireless via Bluetooth interface. With the **AUMA Cloud**, we provide an interactive platform to collect and assess e.g. detailed device data of all actuators within a plant.

Figure 2: Communication via Bluetooth

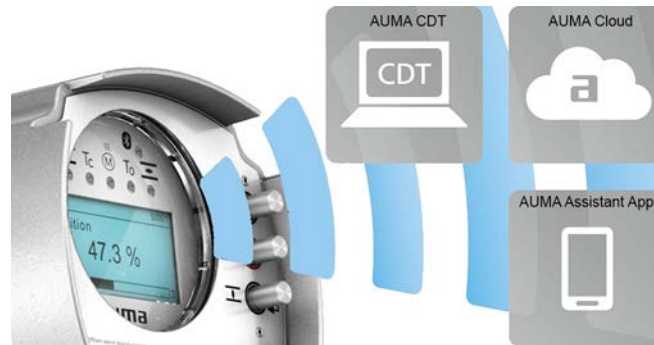

AUMA CDT



AUMA CDT is a user-friendly setting and operation program for AUMA actuators. AUMA CDT software can be downloaded free of charge from our website www.auma.com.

AUMA Cloud



The AUMA Cloud is the driving element of the digital AUMA world, acting as interactive platform for efficient maintenance of AUMA actuators at moderate cost. The AUMA Cloud collects all device data of all actuators within one site and provides a clear overview at a glance. Detailed analysis provides valuable information on potential maintenance requirements. Additional functions foster smooth asset management.

AUMA Assistant App



The AUMA Assistant App enables remote setting and remote diagnostics of AUMA actuators via Bluetooth using either smartphone or tablet.

The AUMA Assistant App can be downloaded free of charge from the Play Store (Android) or App Store (iOS).

Figure 3: Link to AUMA Assistant App



3. Name plate

Figure 4: Arrangement of name plates

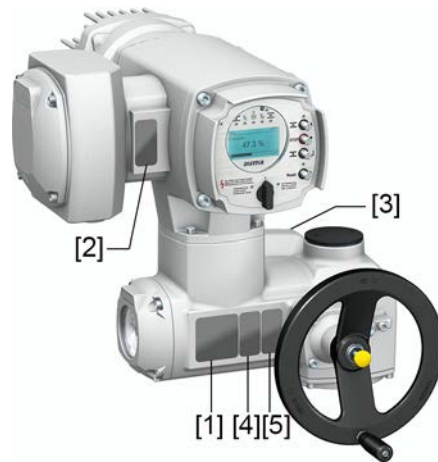

- [1] Actuator name plate
- [2] Actuator controls name plate
- [3] Motor name plate
- [4] Explosion protection approval plate
- [5] Additional plate, e.g. KKS plate (Power Plant Classification System)

Actuator name plate

Figure 5: Actuator name plate (example)



auma (= manufacturer logo); **CE** (= CE mark)

- [1] Name of manufacturer
- [2] Address of manufacturer
- [3] **Type designation**
- [4] **Order number**
- [5] **Serial number**
- [6] Speed range
- [7] Torque range in direction CLOSE
- [8] Torque range in direction OPEN
- [9] Type of lubricant
- [10] Permissible ambient temperature
- [11] Can be assigned as an option upon customer request
- [12] Enclosure protection
- [13] Data Matrix code

Actuator controls name plate

Figure 6: Name plate for actuator controls (example)

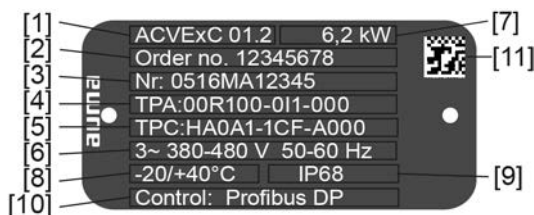

auma (= manufacturer logo)

- [1] **Type designation**
- [2] **Order number**
- [3] **Serial number**
- [4] **Actuator terminal plan**
- [5] Actuator controls terminal plan
- [6] Mains/voltage range/frequency range
- [7] **Rated motor power of ACVExC**
- [8] Permissible ambient temperature
- [9] Enclosure protection
- [10] **Control**
- [11] Data Matrix code

Motor name plate

Figure 7: Motor name plate (example)

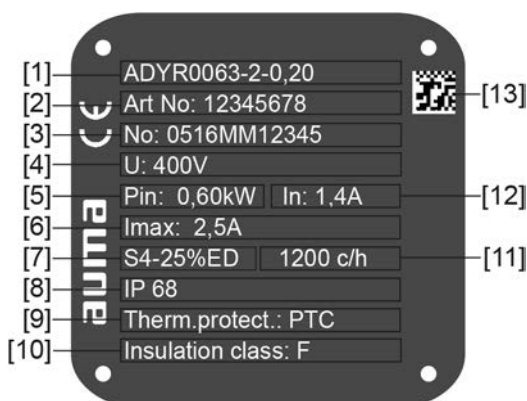

auma (= manufacturer logo); **CE** (= CE mark)

- [1] Motor type
- [2] Motor article number
- [3] Serial number
- [4] Rated voltage
- [5] Consumed nominal power by the mains P_N
- [6] Consumed nominal current by the mains I_N
- [7] Type of duty
- [8] Enclosure protection
- [9] Motor protection (temperature protection)
- [10] Insulation class
- [11] Perm. number of starts (for SARVEx)
- [12] Rated current
- [13] Data Matrix code

Approval plate in explosion-proof version

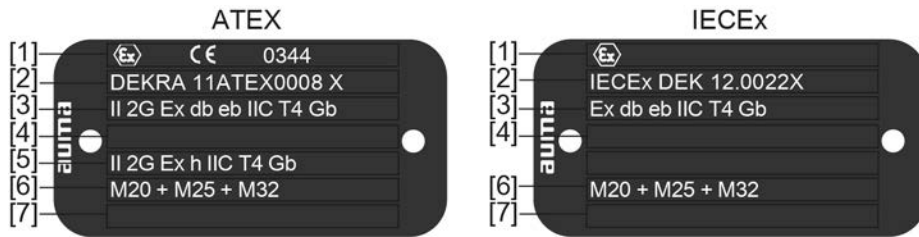

- [1] Ex symbol, CE mark, number of test authority
- [2] Ex certificate (number)
- Classification:
- [3] Electrical gas explosion protection
- [4] Not used
- [5] Non-electrical explosion protection
- [6] Threads for line bushings at electrical connection
- [7] Not used

Descriptions referring to name plate indications

Table 1:

Description of type designation (with the example of SAVEx 07.2-F10)			
SAVEx	07.2	-F10	
SAVEx			Type SA = Multi-turn actuators for open-close duty Type SAR = Multi-turn actuators for modulating duty V = Variable speed Ex = explosion-proof version
	07.2		Size These instructions apply to sizes 07.2, 07.6, 10.2, 14.2, 14.6, 16.2
		F10	Flange size

Table 2:

Description of actuator controls type designation (with the example of ACVExC 01.2)			
ACVExC	01.2		
ACVExC			Type AC = Actuator controls V = variable speed ExC = explosion-proof version
	01.2		Size 01.2

Ex marking

Table 3:

Marking for explosion protection (example of /-a3b1)				
-	a	3	b	1
-	Not used			
	a	Motor type a = ADY: 3-phase AC motor (for 3-phase mains voltage via frequency converter) ASY: 3-phase motor (for 1-phase mains voltage via frequency converter)		
		3	Protection type of electrical connection 3 = Terminal compartment Ex e increased safety 4 = Terminal compartment Ex d flameproof enclosure	
			b	Protection type of position transmitter a = Without intrinsically safe electric circuit b = Electric circuit Ex i Intrinsic safety (RWG 5020.2Ex)
			1	Protection type of fieldbus 1 = Without intrinsically safe Ex ic fieldbus connection 3= Ex ic intrinsically safe fieldbus connection

Order number The product can be identified using this number and the technical data as well as order-related data pertaining to the device can be requested.
 Please always state this number for any product inquiries.

On the Internet at <http://www.auma.com> > Service & Support > myAUMA, we offer a service allowing authorised users to download order-related documents such as wiring diagrams and technical data (both in German and English), inspection certificate and the operation instructions when entering the order number.

Actuator serial number

Table 4:

Description of serial number (example of 0520MD12345)			
05	20	MD12345	
05			Positions 1+2: Assembly in week = week 05
	20		Positions 3+4: Year of manufacture = 2020
		MD12345	Internal number for unambiguous product identification

Actuator terminal plan

Position 9 after **TPA**: Position transmitter version
I, Q = MWG (magnetic limit and torque transmitter)

Control

Table 5:

Control examples (indications on actuator controls name plate)	
Input signal	Description
Profibus DP	Control via Profibus DP interface
Profibus DP/24 V DC	Control via Profibus DP interface and control voltage for OPEN-CLOSE control via digital inputs (OPEN, STOP, CLOSE)

Data Matrix code

When registered as authorised user, you may use our **AUMA Assistant App** to scan the Data Matrix code and directly access the order-related product documents without having to enter order number or serial number.

Figure 8: Link to AUMA Assistant App:



For further Service & Support, Software/Apps/... refer to www.auma.com

4. Transport, storage and packaging

4.1. Transport

For transport to place of installation, use sturdy packaging.

DANGER

Suspended load!

Death or serious injury.

- Do NOT stand below suspended load.
- Attach ropes or hooks for the purpose of lifting by hoist only to housing and NOT to handwheel.
- Actuators mounted on valves: Attach ropes or hooks for the purpose of lifting by hoist to valve and NOT to actuator.
- Actuators mounted to gearboxes: Attach ropes or hooks for the purpose of lifting by hoist only to the gearbox using eyebolts and NOT to the actuator.
- Actuators mounted to controls: Attach ropes or hooks for the purpose of lifting by hoist only to the actuator and NOT to the controls.
- Respect total weight of combination (actuator, actuator controls, gearbox, valve)
- Secure load against falling down, sliding or tilting.
- Perform lift trial at low height to eliminate any potential danger e.g. by tilting.

Figure 9: Example: Lifting the actuator



NOTICE

Delicate cooling fins, risk of damage!

During transport or assembly without the supplied transport protection, the cooling fins may either break or bend if they hit other objects during inappropriate transport.

- During transport and installation, leave the supplied cooling fin transport protection on the cooling fins.

Table 6:

Weights of multi-turn actuators SAVEx 07.2 – SAVEx 16.2 / SARVEx 07.2 – SARVEx 16.2 with 3-phase AC motors		
Type designation Actuator	Motor type ¹⁾	approx. [kg] Weight ²⁾
SAVEx 07.2/ SARVEx 07.2	ADY...	23
SAVEx 07.6/ SARVEx 07.6	ADY...	24
SAVEx 10.2/ SARVEx 10.2	ADY...	28
SAVEx 14.2/ SARVEx 14.2	ADY...	51
SAVEx 14.6/ SARVEx 14.6	ADY...	56
SAVEx 16.2/ SARVEx 16.2	ADY...	82

1) Refer to motor name plate

2) Indicated weight includes AUMA NORM multi-turn actuator with 3-phase AC motor, electrical connection in standard version, output drive type B1 and handwheel. For other output drive types, heed additional weights.

Table 7:

Weights for output drive type		
Type designation	Flange size	[kg]
A 07.2	F07	1.1
	F10	1.3
A 10.2	F10	2.8
A 14.2	F14	6.8
A 16.2	F16	11.7

Table 8:

Weights for output drive type		
Type designation	Flange size	[kg]
AF 07.2	F10	5.2
AF 07.6	F10	5.2
AF 10.2	F10	5.5
AF 14.2	F14	13.7
AF 16.2	F16	23

4.2. Storage

NOTICE

Danger of corrosion due to inappropriate storage!

- Store in a well-ventilated, dry room.
- Protect against floor dampness by storage on a shelf or on a wooden pallet.
- Cover to protect against dust and dirt.
- Apply suitable corrosion protection agent to uncoated surfaces.

NOTICE

Risk of damage due to excessively low temperatures!

- Actuator controls may only be stored permanently down to –30 °C.
- On request, actuators controls may be transported in specific cases and for short duration at temperatures down to –60 °C.

- Long-term storage** For long-term storage (more than 6 months), observe the following points:
1. Prior to storage:
Protect uncoated surfaces, in particular the output drive parts and mounting surface, with long-term corrosion protection agent.
 2. At an interval of approx. 6 months:
Check for corrosion. If first signs of corrosion show, apply new corrosion protection.

5. Assembly

5.1. Mounting position

When using grease as lubricant, the product described herein can be operated in any mounting position.

When using oil instead of grease within the actuator gear housing, perpendicular mounting position is specified whereby the flange is pointing downward. The type of lubricant used is indicated on the actuator name plate (short designation **F**...= grease; **O**...= oil).

5.2. Handwheel fitting

To avoid transport damage, handwheels are supplied separately as appropriate. In this instance, the handwheel must be mounted prior to commissioning.

Figure 10: Handwheel

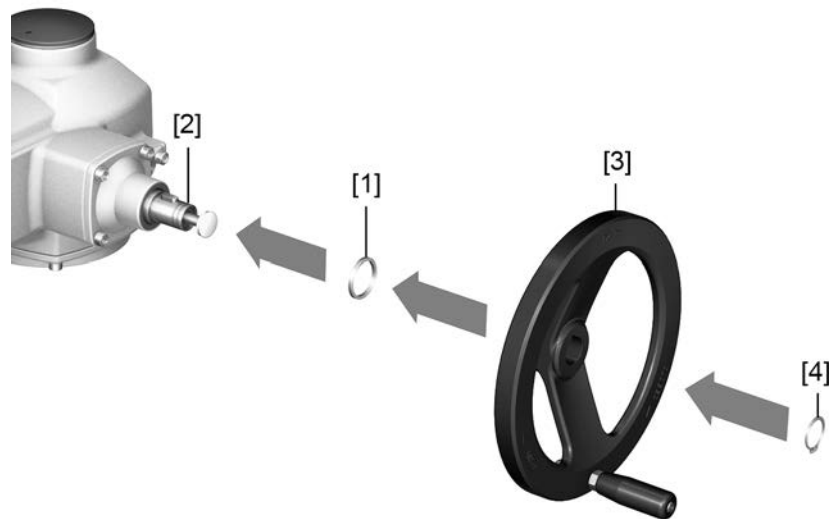

- [1] Spacer
- [2] Input shaft
- [3] Handwheel
- [4] Retaining ring

- How to proceed**
1. If required, fit spacer [1] on input shaft [2].
 2. Slip handwheel [3] onto input shaft.
 3. Secure handwheel [3] with retaining ring [4].

Information: The retaining ring [4] (together with these operation instructions) is stored in a weatherproof bag, which is attached to the device prior to delivery.

5.3. Mount actuator to valve

NOTICE

Corrosion due to damage to paint finish and condensation!

- Touch up damage to paint finish after work on the device.
- After mounting, connect the device immediately to electrical mains to ensure that heater minimises condensation.

5.3.1. Overview of output drive types

Table 9: Overview on output drive types

Valve attachment	Application	Description	Assembly
A	<ul style="list-style-type: none"> for rising, non-rotating valve stem capable of withstanding thrust not appropriate for radial forces 	⇒ page 18, Output drive type A	⇒ page 19, Multi-turn actuator with output drive type A: mount
B, B1 – B4 C D E	<ul style="list-style-type: none"> for rotating, non-rising valve stem not capable of withstanding thrust 	⇒ page 22, Output drive types B/C/D and E	⇒ page 23, Multi-turn actuator with output drive type B: mount

5.3.2. Output drive type A

Figure 11: Output drive type A

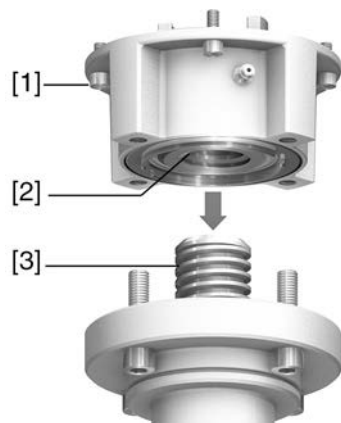

- [1] Output mounting flange
- [2] Stem nut
- [3] Valve stem

Short description Output drive type A consisting of output mounting flange [1] with axial bearing stem nut [2]. The stem nut transmits the torque from the actuator hollow shaft to the valve stem [3]. Output drive type A can withstand thrusts.

To adapt the actuators to available output drive types A with flanges F10 and F14 (year of manufacture 2009 and earlier), an adapter is required. The adapter can be ordered from AUMA.

5.3.2.1. Multi-turn actuator with output drive type A: mount

1. If output drive type A is already mounted to the multi-turn actuator: Loosen screws [3] and remove output drive type A [2].

Figure 12: Multi-turn actuator with output drive type A



- [1] Multi-turn actuator
- [2] Output drive type A, from left to right:
with finish-machined, unbores and pilot bore stem nut
- [3] Screws to multi-turn actuator

Information For an unbores or pilot bore stem nut, the stem nut must be finish machined prior to mounting valve stem and prior to performing the following steps. → [page 21, Stem nut for output drive type A: finish machining](#)

2. Apply a small quantity of grease to the valve stem.
3. Place output drive type A [2] on valve stem and turn until it is [4] flush on the valve flange.
4. Turn output drive type A [2] until alignment of the fixing holes.
5. Fasten screws [5] between valve and output drive type A [2] without completely tightening them.

Figure 13:

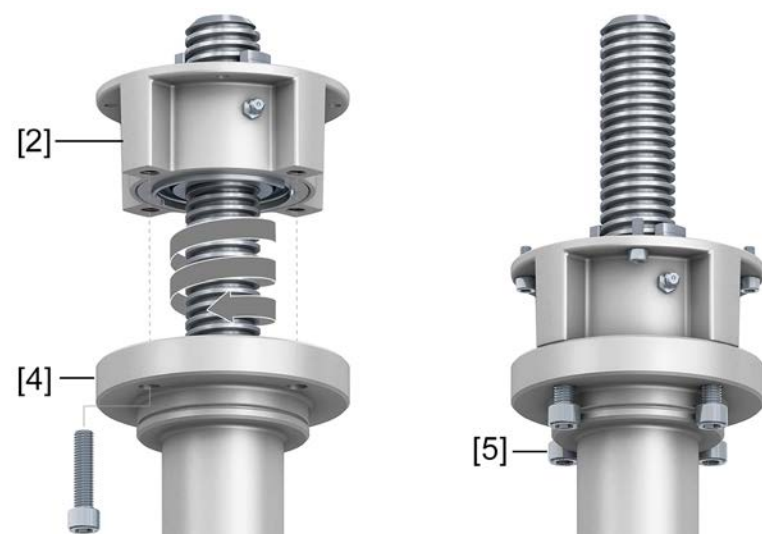

- Fit multi-turn actuator on the valve stem so that the stem nut dogs engage into the output drive sleeve.

Figure 14:

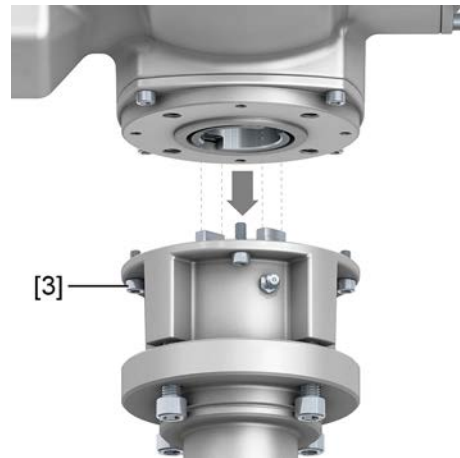

- The flanges are flush with each other if properly engaged.
- Adjust multi-turn actuator until alignment of the fixing holes.
 - Fasten multi-turn actuator with screws [3].
 - Fasten screws [3] crosswise with a torque according to table.

Table 10:

Tightening torques for screws	
Threads	Tightening torque [Nm]
	Strength class A2-80/A4-80
M8	24
M10	48
M16	200
M20	392

- Turn multi-turn actuator with handwheel in direction OPEN until valve flange [4] and output drive type A [2] are firmly placed together.

Figure 15:

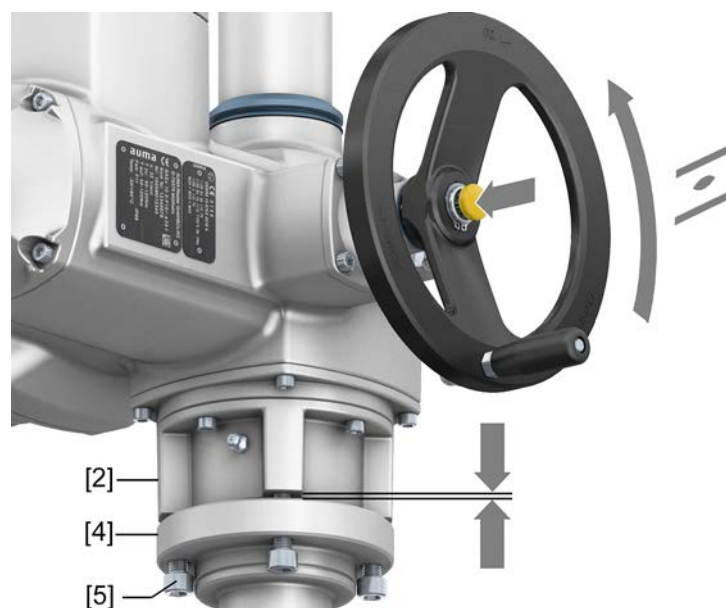

- Tighten screws [5] between valve and output drive type A crosswise applying a torque according to table.

5.3.2.2. Stem nut for output drive type A: finish machining

This working step is only required if stem nut is supplied unbored or with pilot bore.

Information For exact product version, please refer to the order-related technical data sheet or the AUMA Assistant App.

Figure 16: Output drive type A

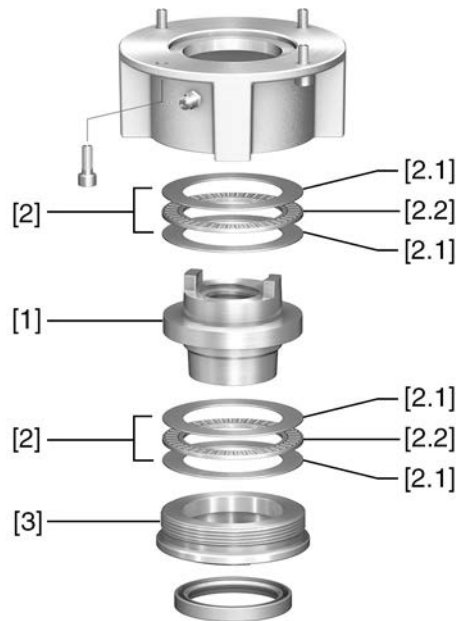

- [1] Stem nut
- [2] Axial needle roller bearing
- [2.1] Axial bearing washer
- [2.2] Axial needle roller and cage assembly
- [3] Spigot ring

- Procedure**
1. Remove spigot ring [3] from output drive.
 2. Remove stem nut [1] together with axial needle roller bearings [2].
 3. Remove axial bearing washers [2.1] and axial needle roller and cage assemblies [2.2] from stem nut [1].
 4. Drill and bore stem nut [1] and cut thread.
 5. Clean the machined stem nut [1].
 6. Apply sufficient Lithium soap EP multi-purpose grease to axial needle roller and cage assemblies [2.2] and axial bearing washers [2.1], ensuring that all hollow spaces are filled with grease.
 7. Place greased axial needle roller and cage assemblies [2.2] and axial bearing washers [2.1] onto stem nut [1].
 8. Re-insert stem nut [1] with axial needle roller bearings [2] into output drive.
 9. Screw in spigot ring [3] until it is firm against the shoulder.

5.3.3. Output drive types B/C/D and E

Figure 17: Mounting principle

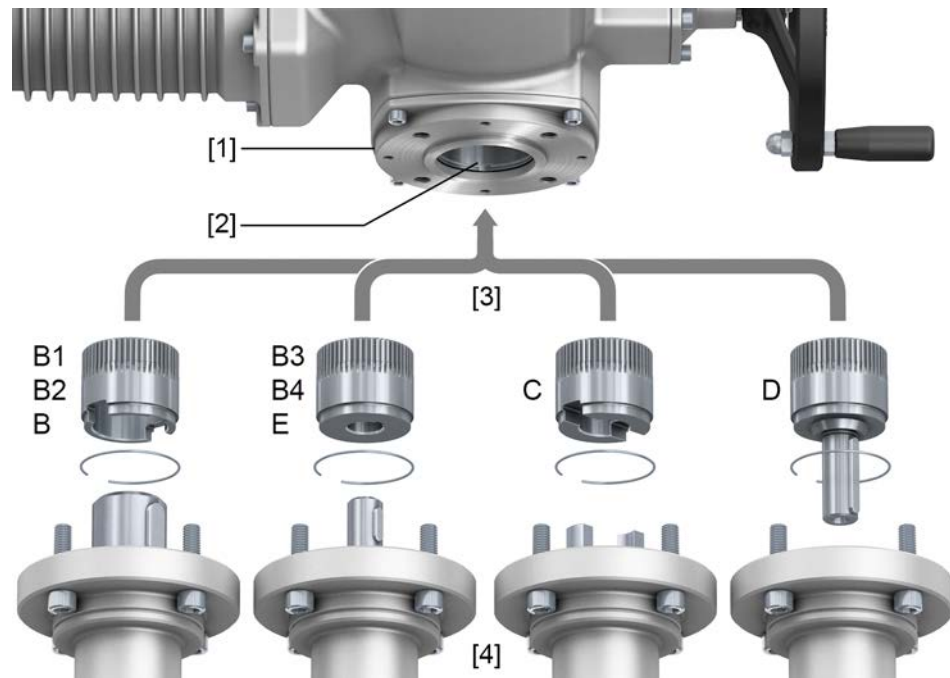

- [1] Flange multi-turn actuator (e.g. F07)
- [2] Hollow shaft
- [3] Output drive sleeve (illustration examples)
- [4] Gearbox/valve shaft

Short description Connection between hollow shaft and valve or gearbox via output drive sleeve fixed to the hollow shaft of the multi-turn actuator via retaining ring.

When exchanging the output drive sleeve, later retrofitting to a different output drive type is possible

- Output drive type B/E:
Output drive sleeve with bore according to DIN 3210
- Output drive types B1/B3:
Output drive sleeve with bore according to EN ISO 5210
- Output drive types B2/B4:
Output drive sleeve with bore according to customer order
B4 including special bores like bores without keyway, square bore, hexagon bore, internal splines
- Output drive type C:
Output drive sleeve with dog coupling according to EN ISO 5210 or DIN 3338
- Output drive type D:
Shaft end with key according to EN ISO 5210 or DIN 3210

Information Spigot at valve flanges should be loose fit.

5.3.3.1. Multi-turn actuator with output drive type B: mount

Figure 18: Mounting output drive types B

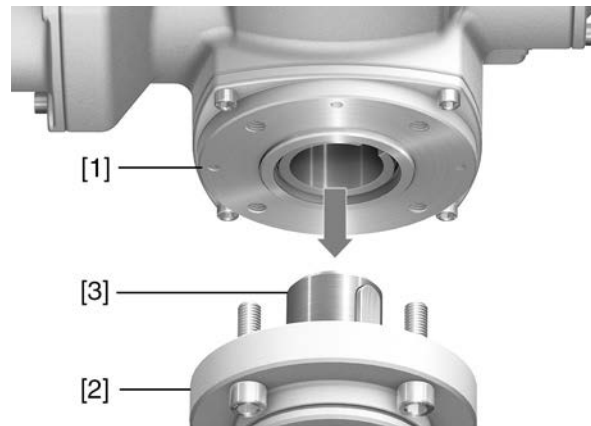

- [1] Multi-turn actuator
- [2] Valve/gearbox
- [3] Valve/gearbox shaft

Procedure

1. Check if mounting flanges fit together.
2. Check if output drive of multi-turn actuator [1] matches the output drive of valve/gearbox or valve/gearbox valve shaft [2/3].
3. Apply a small quantity of grease to the valve or gearbox shaft [3].
4. Place multi-turn actuator [1] and ensure that the spigot fits uniformly in the recess and that the mounting faces are in complete contact.
5. Fasten multi-turn actuator with screws according to table.
Information: We recommend applying liquid thread sealing material to the screws to avoid contact corrosion.
6. Fasten screws crosswise to a torque according to table.

Table 11:

Tightening torques for screws	
Threads	Tightening torque [Nm]
	Strength class A2-80/A4-80
M8	24
M10	48
M16	200
M20	392

5.4. Accessories for assembly

5.4.1. Stem protection tube for rising valve stem

Figure 19: Assembly of the stem protection tube

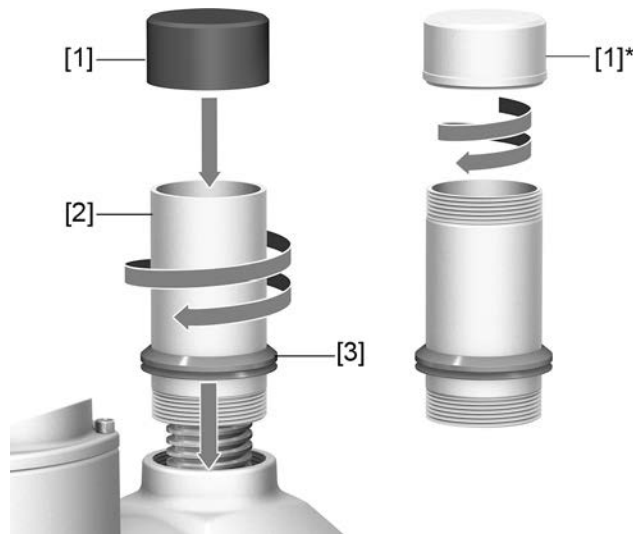

- [1] Protective cap for stem protection tube (fitted)
- [1]* Option: Protective cap made of steel (screwed)
- [2] Stem protection tube
- [3] V-seal

- Procedure**
1. Seal all threads with hemp, Teflon tape, sealing agent or thread sealing material.
 2. Screw stem protection tube [2] into thread and tighten it firmly.
- Information:** For stem protection tubes made of two or more segments, all parts have to be thoroughly screwed together.

Figure 20: Protection tube made of segments with threaded sleeves (>900 mm)

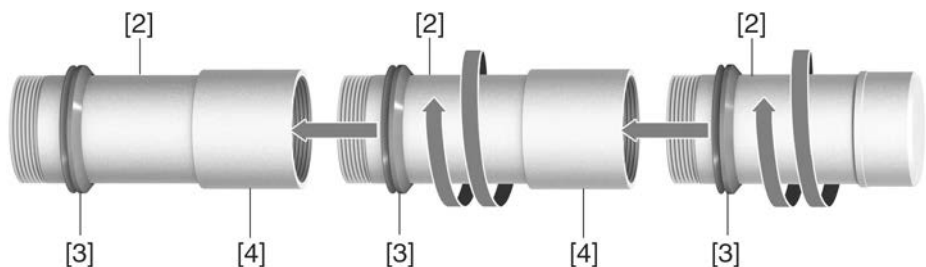

- [2] Segment of stem protection tube
- [3] V-seal
- [4] Threaded sleeve

3. Push down the sealing ring [3] onto the housing.
- Information:** For mounting segments, push down seals of segments down to the sleeve (connecting piece).
4. Check whether protective cap [1] for stem protection tube is available, in perfect condition and tightly placed on or screwed to the tube.

NOTICE

Risk of bending or oscillation of protection tubes exceeding a length of 2 m!

Risk of damage at stem and/or protection tube.

→ Secure protection tubes exceeding 2 m by an appropriate support.

5.5. Mounting positions of local controls

Figure 21: Mounting positions



The mounting position of the local controls is implemented according to the order. If, after mounting the actuator to the valve or the gearbox on site, the local controls are in an unfavourable position, the mounting position can be changed at a later date. Four mounting positions shifted by respectively 90° are possible (by maximum 180° into one direction).

5.5.1. Mounting positions: modify



WARNING

Ignition of potentially explosive atmospheres caused by sparks.

Risk of death or serious injury.

- Before opening the flameproof enclosure, ensure absence of gas and voltage.
- Wait for 30 seconds after power cut-off prior to opening the housing.
- Handle cover and housing parts with care.
- Joint surfaces must not be damaged or soiled in any way.
- Do not jam cover during fitting.

NOTICE

Electrostatic discharge ESD!

Risk of damage to electronic components.

- Earth both operators and devices.

1. Loosen screws and remove the local controls.
2. Check whether O-ring is in good condition, correctly insert O-ring.
3. Turn local controls into new position and re-place.

NOTICE

Cable damage due to twisting or pinching!

Risk of functional failures.

- Turn local controls by a maximum of 180°.
- Carefully assemble local controls to avoid pinching the cables.

4. Fasten screws evenly crosswise.

6. Electrical connection

6.1. Basic information



WARNING

Electric shock due to presence of hazardous voltage!

Failure to observe this warning can result in death, serious injury, or property damage.

- The electrical connection must be carried out exclusively by suitably qualified personnel.
- Prior to connection, observe basic information contained in this chapter.
- After connection but prior to applying the voltage, observe the <Commissioning> and <Test run> chapters.



NOTICE

Risk of overheating during operation with mounted transport protection!

- Prior to connection, remove transport protection from cooling fins.

Figure 22: Remove transport protection

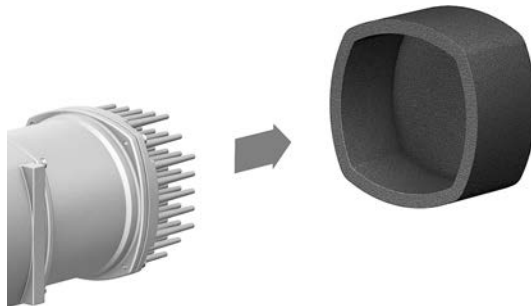

Wiring diagram/terminal plan

The pertaining wiring diagram/terminal plan (in German or English) is attached to the device in a weather-proof bag, together with these operation instructions. It can also be requested from AUMA (state order number, refer to name plate) or downloaded directly from the Internet (<http://www.auma.com>).

Permissible networks (supply networks)

The actuators are suitable for use in TN and TT networks with directly grounded star point for nominal voltages up to maximum 480 V AC. Use in IT network is permissible for nominal voltages up to maximum 480 V AC. For IT network, a suitable, approved insulation monitor measuring the pulse code is required.

Current type, mains voltage, mains frequency

Type of current, mains voltage and mains frequency must match the data on the actuator controls and motor name plates. Also refer to chapter <Identification>/<Name plate>.

Figure 23: Actuator controls name plate (example)

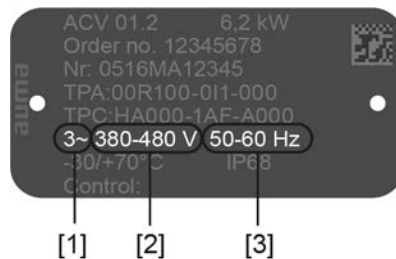

- [1] Type of current
- [2] Mains voltage (voltage range)
- [3] Mains frequency (frequency range)

Protection and sizing on site

For short-circuit protection and for disconnecting the actuator from the mains, fuses and disconnect switches have to be provided by the customer.

Table 12:

Protection on site				
Multi-turn actuator	3-phase AC motor 380 V – 480 V/50 Hz – 60 Hz ¹⁾			Fuse ²⁾
Type	Consumed rated power P_{IN} [kW]	Rated current I_N [A]	Max. current I_{max} [A]	Blow characteristics: Time-delay (gG) [A]
SAVEx 07.2	0.6	1.3	1.8	6
SARVEx 07.2	0.6	1.3	2.5	6
	0.7	1.5	3.5	6
SAVEx 07.6	0.9	2.0	2.8	6
SARVEx 07.6	1.1	2.3	4.3	6
	1.2	2.7	4.8	6
SAVEx 10.2	1.3	2.8	4.4	6
SARVEx 10.2	1.6	3.6	6.9	10
	1.8	4.0	7.4	10
SAVEx 14.2	1.7	3.8	6.1	10
SARVEx 14.2	2.8	6.1	11.0	16
	3.5	7.8	15.2	20
SAVEx 14.6	2.9	6.5	9.9	16
SARVEx 14.6	4.5	9.9	17.9	20
	5.6	12.3	22.6	25
SAVEx 16.2	5.3	10.9	17.2	20
SARVEx 16.2				

- 1) For motor with different current type/mains voltage/mains frequency (refer to motor name plate). Select fuse referring to the Electrical data sheet.
- 2) The actuators are suitable for use in current circuits with a maximum short-circuit 1-phase AC current value of 5,000 A root-mean-square (R.M.S). The output data of the fuses to be provided on site must not exceed the following values: 32 A/600 V at a maximum mains short-circuit alternating current of 5,000 A AC.

Consider the max. current (I_{max}) (refer to motor name plate or electrical data sheet) when selecting the circuit breaker.

We recommend refraining from using residual current devices (RCD). However, if an RCD is used within the mains, the residual current device must be of type B. DC current may be present within the PE conductor.

Implementation of overcurrent protection devices is not required. Actuator controls are equipped with own protection mechanisms, adapted to the actuator system. Therefore, we recommend refraining from using overcurrent protection devices.

For actuator controls equipped with a heating system and external electronics power supply, the fuses for the heating system have to be provided by the customer (refer to wiring diagram F4 ext.)

Table 13:

Fuse for heating system		
Designation in wiring diagram = F4 ext.		
External power supply	115 V AC	230 V AC
Fuse	2 A T	1 A T

If actuator controls are mounted separately from actuator (actuator controls on wall bracket): Consider length and cross section of connecting cable when defining the protection required.

Potential of customer connections

Refer to Technical data for options of isolated potentials.

Safety standards Safety measures and safety equipment must comply with the respectively valid national on site specifications. All externally connected devices shall comply with the relevant safety standards applicable for the place of installation.

- Connecting cables, cable glands, reducers, blanking plugs**
- We recommend using connecting cables and connecting terminals according to rated current (I_N) (refer to motor name plate or electrical data sheet).
 - For device insulation, appropriate (voltage-proof) cables must be used. Specify cables for the highest occurring rated voltage.
 - Use connecting cables, cable glands, reducers, blanking plugs with a minimum temperature range of +80 °C.
 - To avoid contact corrosion, we recommend the use of sealing agents for cable glands and blanking plugs made of metal.
 - For connecting cables exposed to UV radiation (outdoor installation), use UV resistant cables.
 - For the connection of position transmitters, screened cables must be used.

Cable installation in accordance with EMC Signal and fieldbus cables are susceptible to interference. Motor cables are interference sources.

NOTICE

This product potentially causes high frequency interference!

→ The measures eliminating interference described hereafter must be observed for cable installation in accordance with EMC.

- Use shielded power cable and earth shield at both ends.
- Lay cables being susceptible to interference or sources of interference at the highest possible distance from each other.
- The interference immunity of signal and fieldbus cables increases if the cables are laid close to the earth potential.
- If possible, avoid laying long cables and make sure that they are installed in areas being subject to low interference.
- Avoid parallel paths with little cable distance of cables being either susceptible to interference or interference sources.
- In a residential environment, this product may cause radio interference, in which case supplementary mitigation measures might be required.

Fieldbus cable

Table 14:

Cable recommendation	
Only cables complying with IEC 61158 or IEC 61784, cable type A, may be used for Profibus DP wiring.	
Impedance	135 to 165 Ohm, at a measurement frequency between 3 and 20 MHz
Cable capacity	< 30 pF per metre
Wire diameter	> 0.64 mm
Cross section	> 0.34 mm ² , corresponds to AWG 22
Loop resistance	< 110 Ohm per km
Screening	CU shielding braid or shielding braid and shielding foil

Prior to installation, please note:



- Connect maximum 32 devices to one segment.
- If more devices are to be connected:
 - Allot devices to different segments.
 - Connect segments using repeaters.
- Install fieldbus cables at a distance of minimum 20 cm to other cables.
- If possible, fieldbus cables should be laid in a separate, conductive, and earthed cable tray.
- Ensure absence of equipotential earth bonding differences between the individual devices at fieldbus (perform an equipotential earth bonding).

Baud rate [kbit/s]	≥ 93.75	187.5	500	1,500
Maximum segment length [m]	1,200	1,000	400	200

6.2. Overview of AUMA electrical connections

The section below provides an overview of the different electrical connections described in the chapters to follow.

Table 15: Versions of the AUMA plug/socket connector

Electrical connection	Figure	Properties	For description and assembly refer to chapter
KT		Plug-in integral terminal connection with enlarged terminal compartment	⇒ page 30, KT/KM electrical connection
KP		Plug/socket connector with terminal board	⇒ page 37, KP/KPH electrical connection
KES		Plug-in terminal connection with enlarged terminal compartment	⇒ page 42, KES electrical connection

6.3. KT/KM electrical connection

Figure 24: KT/KM electrical connection

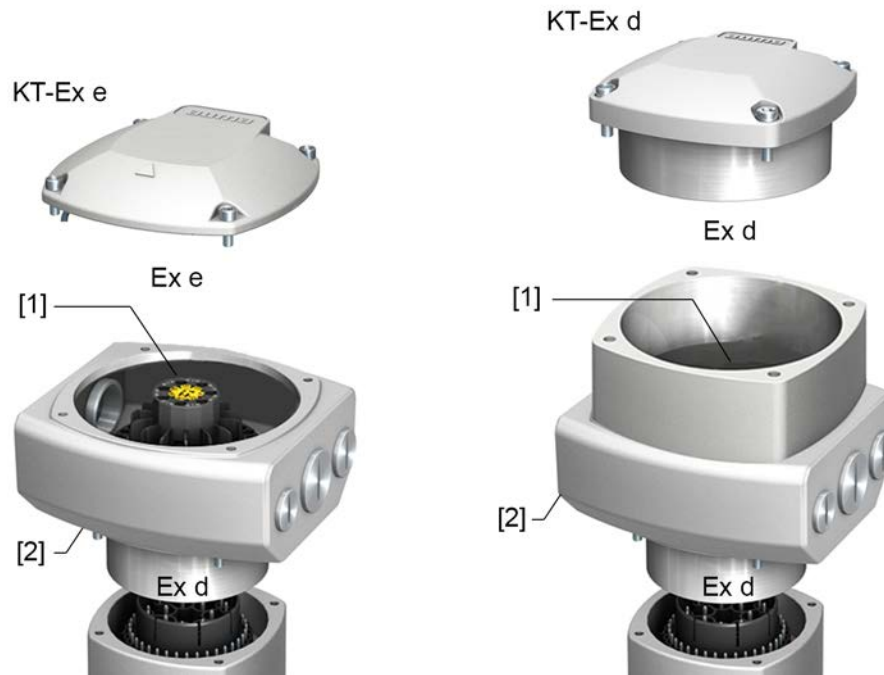

- [1] Terminal carrier with screw-type/spring clamp terminals
 - [2] Connection frame
- Figure shows KT version

Short description KT plug-in electrical connection with screw-type terminals for power connection and spring clamp terminals for control contacts.

KM version with additional support terminals (terminal blocks) via terminal carrier. When using solid fieldbus cables in line topology, imperatively use support terminals.

Both versions (KT and KM) are available with terminal compartment in protection type Ex e (increased safety) as well as in protection type Ex d (flameproof enclosure) (refer to Ex marking on name plate).

Plug-in connection is made via the connection frame. For cable connection, simply remove the cover. The connection frame with the cable entries remains within the device. The flameproof interior of the connected devices remains sealed.

Technical data

Table 16:

KT/KM/KL electrical connection		
	Power contacts	Control contacts
No. of contacts max.	6 + PE conductors ¹⁾	50
Designations	U1, V1, W1, U2, V2, W2, ⊕	1 to 36, 37 to 50
Support terminals max.	3	12
Connection voltage max.	1,000 V	250 V
Rated current max.	25 A	5 A ²⁾
Type of customer connection	Screw connection PE = Ring lug/U-bracket	Spring clamp terminals
Connection diameter max.	10 mm ²	2.5 mm ²

1) Four protective earth connections within frame
 2) The sum of the currents of all control contacts must not exceed 50 A.

6.3.1. Terminal compartment: open

Figure 25: Open terminal compartment

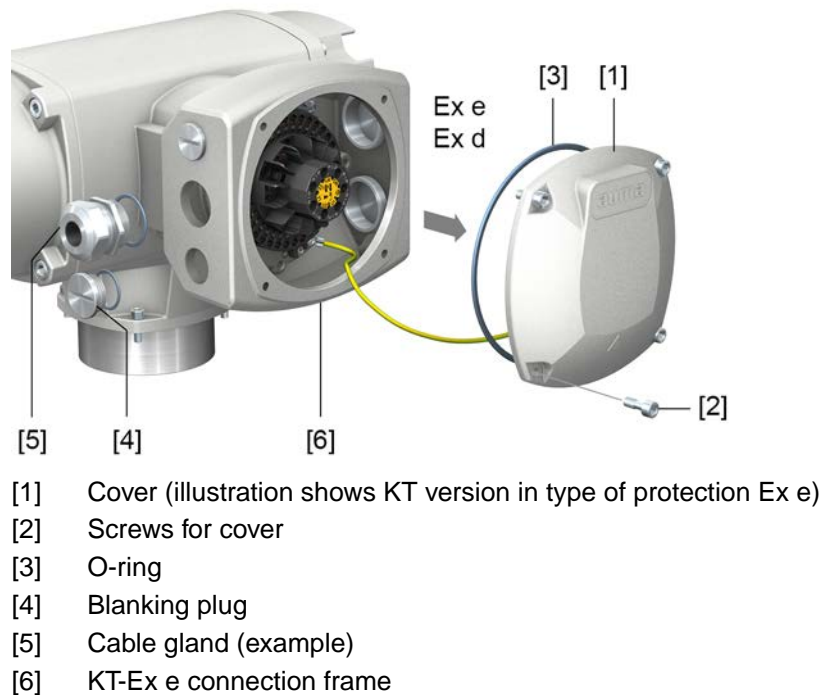

Terminal compartment is designed either in type of protection Ex e (increased safety) or in type of protection Ex d (flameproof enclosure) (refer to Ex marking on name plate). The flameproof interior of the connected device remains closed when removing the cover [1].

Procedure



Electric shock due to presence of hazardous voltage!

Failure to observe this warning results in death or serious injury.

- Disconnect device from the mains before opening.
- Wait for 30 seconds after power cut-off prior to opening the housing.

1. Loosen screws [2] and remove cover [1].
2. Insert cable glands suitable for connecting cables.
Information: When selecting cable glands observe type of protection (with Ex e or Ex d approval) and enclosure protection IP (refer to name plate). The enclosure protection stated on the name plate IP is only ensured if suitable cable glands are used. Thread types and thread sizes are specified on the approval plate in explosion-proof version. Refer to chapter <Identification/name plate>.

Figure 26: Name plate, example with enclosure protection IP68



3. Seal unused cable entries with approved plugs suitable for the required protection type.

6.3.2. Cable connection

Table 17:

Terminal cross sections and tightening torques		
Designation	Terminal cross sections	Connection type
Power contacts (U1, V1, W1, U2, V2, W2) PE connection	Flexible or solid: 0.25 – 10.0 mm ² (for one wire per terminal) Flexible: 2 x 0.25 – 4 mm ² (for two wires per terminal)	Screw-type terminals Tightening torque = 1.2 – 1.5 Nm
Control contacts (1 to 36, 37 to 50)	Flexible or solid: 0.25 – 2.5 mm ² (for one wire per terminal) 2 x 0.25 – 0.75 mm ² (for two wires per terminal)	Spring clamp terminals
Protective earth connection within frame (customer connection)	2 x M6 for cables with M6 ring lug or with U-bracket for up to two wires with 1.5 mm ² – 10 mm ²	Ring lug/U-bracket Tightening torque = 3 – 4 Nm

Procedure

1. Remove cable sheathing in a length of 250 – 300 mm.
2. Insert the wires into the cable glands.
3. Fasten cable glands with the specified torque to ensure required enclosure protection.
Information: For shielded cables: Link the cable shield end via the cable gland to the housing (earthing).
4. Strip wires:
 - 4.1 Remove wire sheathing of control cables (1...50) in a length of approx. 10 mm
 - 4.2 Remove wire sheathing of motor cables (U, V, W) in a length of approx. 12 mm
5. Connect cables according to order-related wiring diagram.

Figure 27: Connect cables to terminal carrier

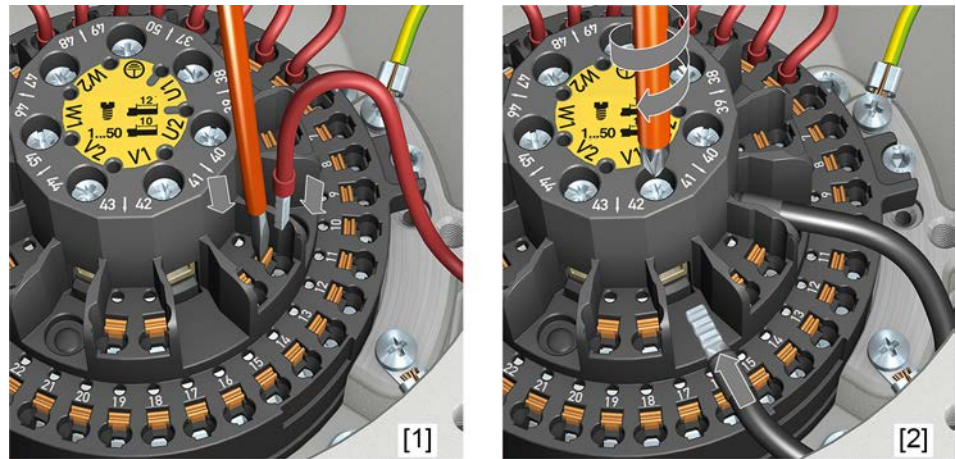

- [1] Fitting control cables into spring clamp terminals
- [2] Tightening power terminals

Information For service purposes, each spring clamp terminal is equipped with a test contact located above the numbering.

Information For flexible cables: for screw-type terminals, use wire end sleeves according to DIN 46228. For spring clamp terminals, connection is possible without wire end sleeves.



In case of a fault: Hazardous voltage while protective earth conductor is NOT connected!

Risk of electric shock.

- Connect all protective earth conductors.
- Connect PE connection to external protective earth conductor of connecting cables.
- Start running the device only after having connected the protective earth conductor.

6. Firmly tighten protective earth to PE connection (M6 ⊕).

Figure 28: Protective earth connections within connection frame

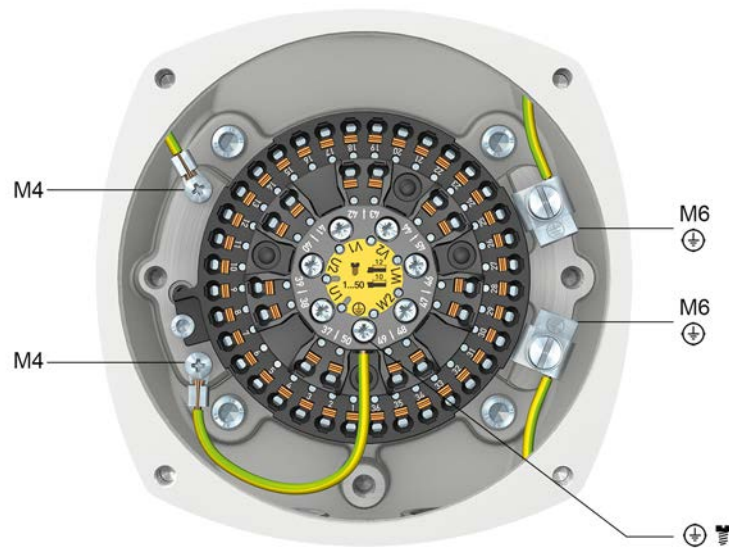

- M6 Customer protective earth connection for M6 ring lug or with U-bracket for up to two wires.
- M4 Internal protective earth connections via M4 ring lug (to cover and terminal carrier) connected in the factory
- ⊕ Protective earth connection to terminal carrier (power terminals); connected in the factory.

6.3.3. Fieldbus cables: connect

6.3.3.1. Fieldbus connection for line topology

Figure 29: Line topology

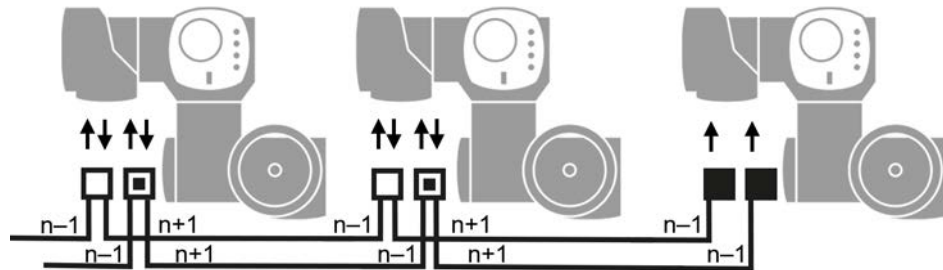

- Channel 1: Further fieldbus devices follow
 - ▣ Channel 2 (redundancy only): further fieldbus devices follow
 - Last fieldbus device
- n-1 Fieldbus cable from previous device (input)
 n+1 Fieldbus cable to next device (output)

Anschluss am Klemmenblock bei Linientopologie

For flexible cables, the fieldbus connection can be made via spring clamp terminals directly at the terminal carrier. For solid cables (single or multiple strands), additional support terminals must be used. Siehe Abschnitt <Anschluss mit Stützpunktklemmen bei Linientopologie>

Information For two flexible wires per terminal, a joint wire end sleeve must be used (twin wire end sleeve).

Figure 30: Terminal assignment at terminal carrier: Kanal 1 (1A/1B)

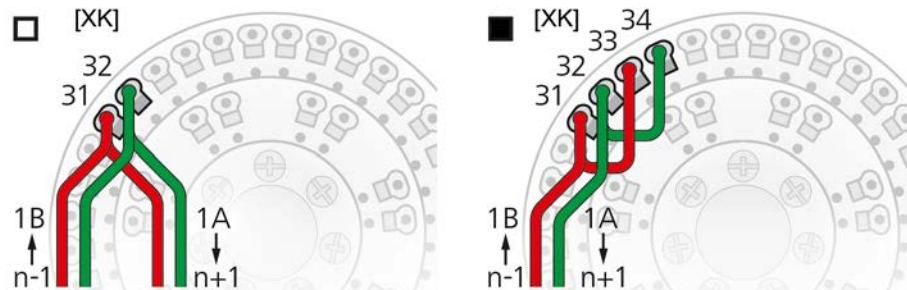
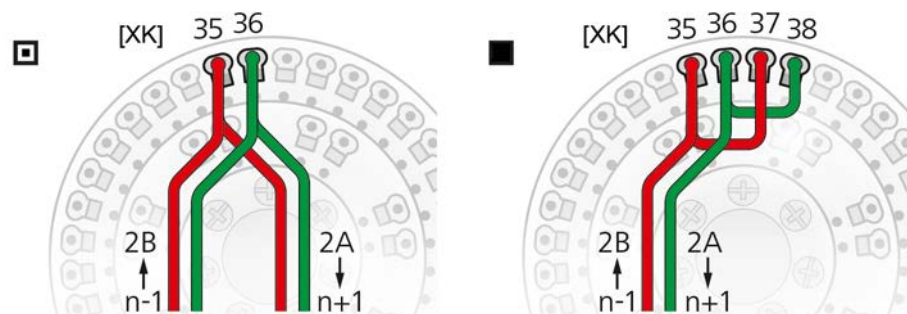

Figure 31: Terminal assignment at terminal carrier: Channel 2 (2A/2B)



- [XK] Terminal assignment according to wiring diagram (customer connection):
- ▣ Channel 1 □ or channel 2 ▣ if further fieldbus devices follow
 - If the actuator is the last fieldbus device:
 Channel 1: Link terminals 31/33 and 32/34
 Channel 2: Link terminals 35/37 and 36/38

Information Always link A connections to green wire and B connections to red wire.

Connection with support terminals for line topology

When using solid cables (single or multiple strands), additional support terminals must be used. The support terminals (terminal blocks) are mounted above the terminal carrier.

Figure 32: Terminal assignment of support terminals: Channel 1 (1A/1B)

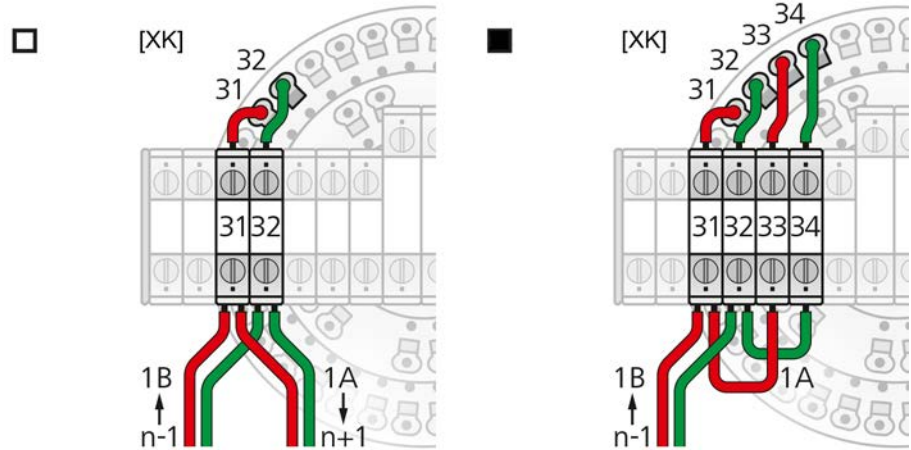

[XK] Terminal assignment according to wiring diagram (customer connection):

- Terminals 31 and 32 if another fieldbus device follows
- Terminals 31 – 34 if the actuator is the last fieldbus device

Figure 33: Terminal assignment of support terminals: Channel 2 (2A/2B)

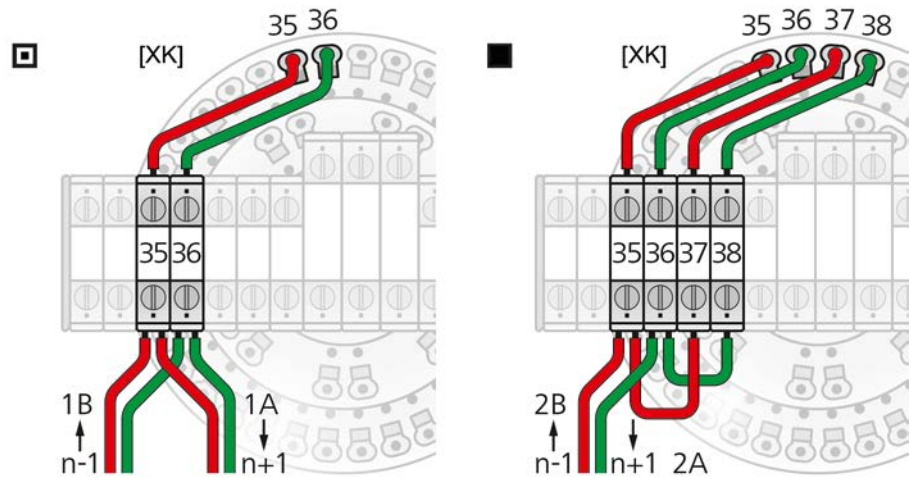

[XK] Terminal assignment according to wiring diagram (customer connection):

- Terminals 35 and 36 if another fieldbus device follows
- Terminals 35 – 38 if the actuator is the last fieldbus device

Information Always link A connections to green wire and B connections to red wire.

6.3.4. Terminal compartment: close

Figure 34: Close terminal compartment

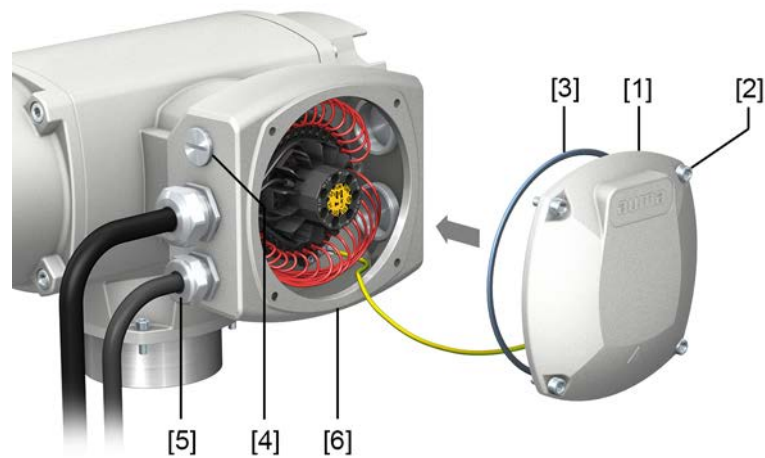

- [1] Cover (illustration shows KT version in type of protection Ex e)
- [2] Screws for cover
- [3] O-ring
- [4] Blanking plug
- [5] Cable gland
- [6] KT-Ex e connection frame

- Procedure**
1. Clean sealing faces of cover [1] and connection frame [6].
 2. For design in flameproof enclosure (Ex d): Preserve joint surfaces with an acid-free corrosion protection agent.
 3. Check whether O-ring [3] is in good condition, replace if damaged.
 4. Apply a thin film of non-acidic grease (e.g. petroleum jelly) to the O-ring and insert it correctly.
 5. Fit cover [1] and fasten screws [2] evenly crosswise.
 For design in flameproof enclosure (Ex d):



Flameproof enclosure, danger of explosion!

Risk of death or serious injury.

- Handle cover and housing parts with care.
- Joint surfaces must not be damaged or soiled in any way.
- Do not jam cover during fitting.

6. Fasten cable glands and blanking plugs applying the specified torque to ensure the required enclosure protection.

6.4. KP/KPH electrical connection

Figure 35: KP and KPH electrical connection

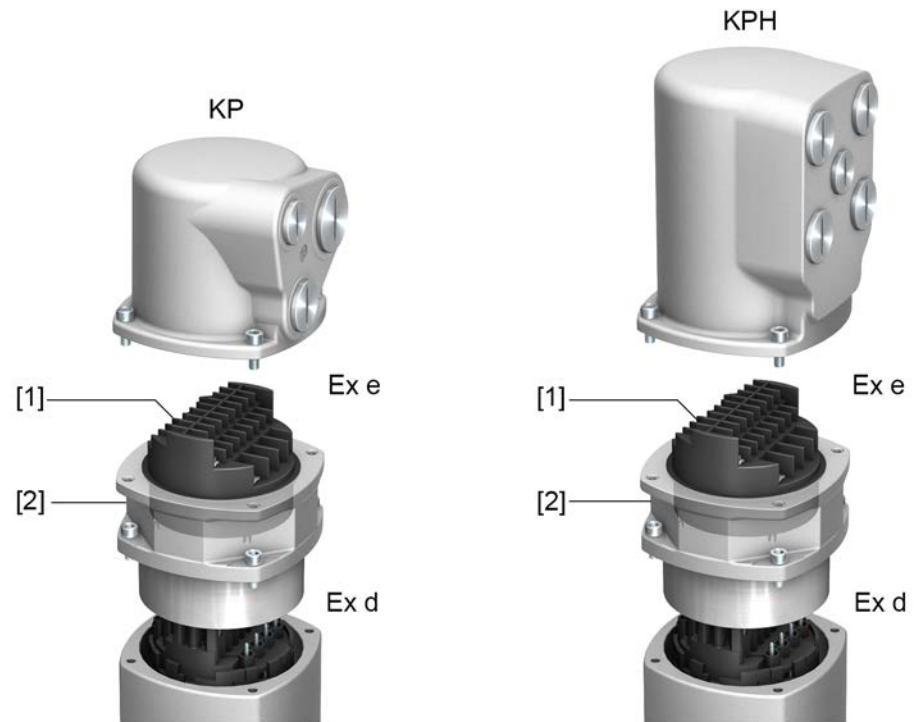

- [1] Screw-type terminals
- [2] Plug-in frame (flameproof)

Short description KP/KPH plug-in electrical connection with screw-type terminals for power and control contacts.

KP version (standard) with three cable entries. KPH version (enlarged) with additional cable entries. Cable entries via the cover.

The terminal compartment (with screw-type terminals) is designed in protection type Ex e (increased safety). Plug-in connection is made via the frame. Removing the cover is sufficient for connecting the cables. The flameproof frame remains connected to the device. The flameproof interior of the connected device remains sealed.

Technical data

Table 18:

KP/KPH electrical connection		
	Power contacts	Control contacts
No. of contacts max.	3 + protective earth conductor (PE)	38 pins/sockets + protective earth conductor (PE)
Designations	U1, V1, W1, ⊕ (PE)	1 to 24, 31 to 40, 47 to 50, PE
Connection voltage max.	525 V	250 V
Rated current max.	25 A	10 A
Type of customer connection	Screw connection	Screw connection
Connection diameter max.	6 mm ²	1.5 mm ²

6.4.1. Terminal compartment: open

Figure 36:

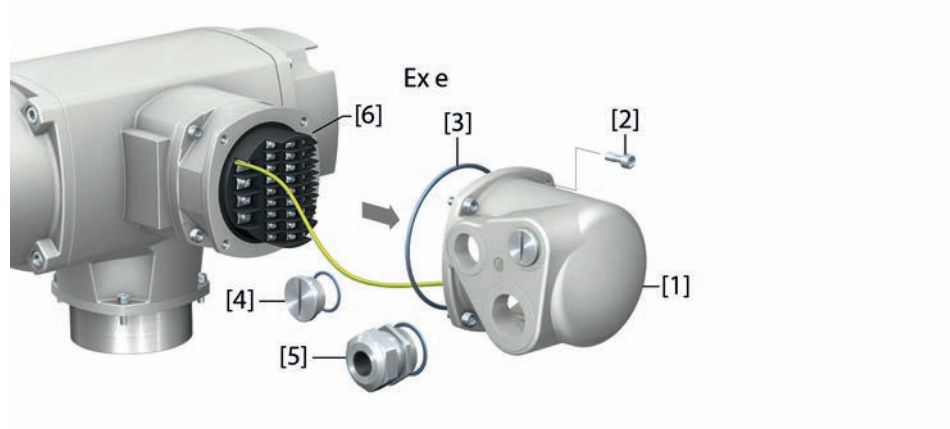

- [1] Cover (figure shows KP version)
- [2] Screws for cover
- [3] O-ring
- [4] Blanking plugs
- [5] Cable gland (example)
- [6] Flameproof frame

Type of protection The terminal compartment is designed in protection type Ex e (increased safety). The flameproof interior of the connected device remains closed when removing the cover [1].

Cable glands When selecting cable glands observe type of protection (with Ex e approval) and enclosure protection IP (refer to name plate).

The enclosure protection IP... stated on the name plate is only ensured if suitable cable glands are used.

Figure 37: Name plate, example with enclosure protection IP68



For shielded cables: Use EMC cable glands.



Electric shock due to presence of hazardous voltage!

Failure to observe this warning results in death or serious injury.

- Disconnect device from the mains before opening.
- Wait for 30 seconds after power cut-off prior to opening the housing.

How to proceed

1. Loosen screws [2] and remove cover [1].
2. Insert cable glands suitable for connecting cables.
3. Seal unused cable entries with approved plugs suitable for the required protection type.

6.4.2. Cable connection

Table 19:

Terminal cross sections and terminal tightening torques		
Designation	Terminal cross sections	Tightening torques
Power contacts (U1, V1, W1)	With small clamp washers:	0.9 – 1.1 Nm
Protective earth connection ⚡ (PE)	1.5 – 4.0 mm ² (flexible or solid)	
	With large clamp washers:	
	2.5 – 6 mm ² (flexible or solid)	
Control contacts (1 to 24, 31 to 40, 47 to 50, PE)	0.75 – 1.5 mm ² (flexible or solid)	0.5 – 0.7 Nm

1. Remove cable sheathing in a length of 120 – 140 mm.
2. Insert the wires into the cable glands.
3. Fasten cable glands with the specified torque to ensure required enclosure protection.
Information: For shielded cables: Link the cable shield end via the cable gland to the housing (earthing).
4. Strip wires.
 → Controls max. 8 mm, motor 12 mm
5. For flexible cables: Use wire end sleeves according to DIN 46228.
6. Connect cables according to order-related wiring diagram.
Information: Two wires for each connection permitted.
 → When using motor cables with wire cross section of 1.5 mm²: Use small clamp washers for connection to terminals U1, V1, W1 and PE (the small clamp washers are in the cover of electrical connection upon delivery).



In case of a fault: Hazardous voltage while protective earth conductor is NOT connected!

Risk of electric shock.

- Connect all protective earth conductors.
- Connect PE connection to external protective earth conductor of connecting cables.
- Start running the device only after having connected the protective earth conductor.

7. Firmly tighten protective earth to PE connection.

Figure 38: PE connection



- [1] PE connection, control cable
- [2] PE connection, motor cable

6.4.3. Fieldbus cables: connect

Figure 39: Terminal assignment for line topology (1-channel or 2-channel for AUMA redundancy I or II)

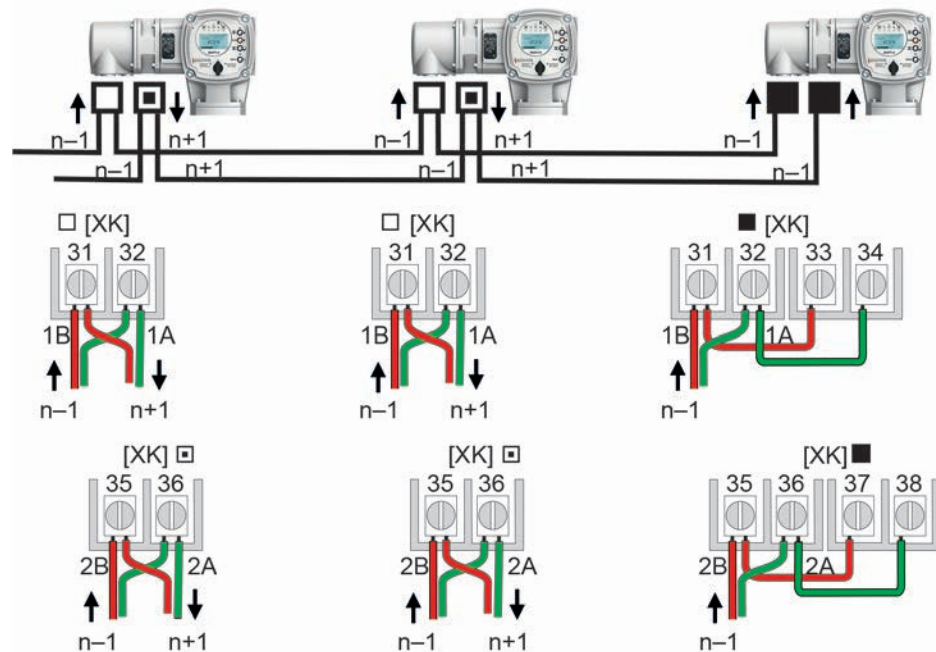

- Channel 1: Further fieldbus devices will follow (standard)
 - ▣ Channel 2: Further fieldbus devices will follow (AUMA redundancy I or II only)
 - Last fieldbus device
- n-1 Fieldbus cable from previous device (input)
 n+1 Fieldbus cable to next device (output)
- [XK] Terminal assignment according to wiring diagram (customer connection):
 Channel 1: Terminals 31, 32 and 33, 34
 Channel 2: Terminals 35, 36 and 37, 38 (AUMA redundancy I or II)

Connect fieldbus cables:

1. Connect bus cables.
 - Always link A connections to green wire and B connections to red wire.
2. If the actuator is the final device in the fieldbus segment (line topology only):
 - 2.1 Connect termination resistor for channel 1 through linking the terminals 31 - 33 and 32 - 34 (standard)
 - 2.2 For AUMA redundancy I or II: Connect termination resistor for channel 2 through linking the terminals 35 - 37 and 36 - 38.

6.4.4. Terminal compartment: close

Figure 40: Close terminal compartment

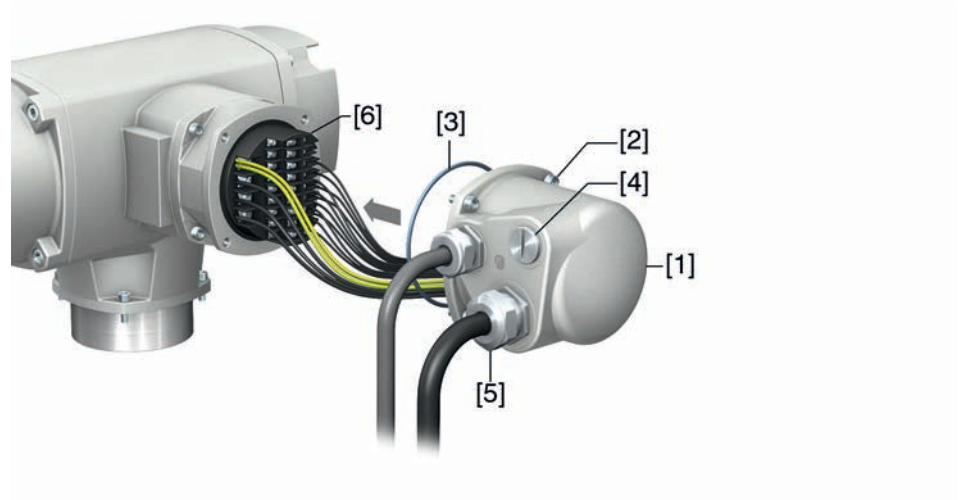

- [1] Cover (figure shows KP version)
- [2] Screws for cover
- [3] O-ring
- [4] Blanking plugs
- [5] Cable gland
- [6] Flameproof frame

1. Clean sealing faces of cover [1] and frame [6].
2. Check whether O-ring [3] is in good condition, replace if damaged.
3. Apply a thin film of non-acidic grease (e.g. petroleum jelly) to the O-ring and insert it correctly.
4. Fit cover [1] and fasten screws [2] evenly crosswise.
5. Fasten cable glands and blanking plugs applying the specified torque to ensure the required enclosure protection.

6.5. KES electrical connection

Figure 41: KES electrical connection

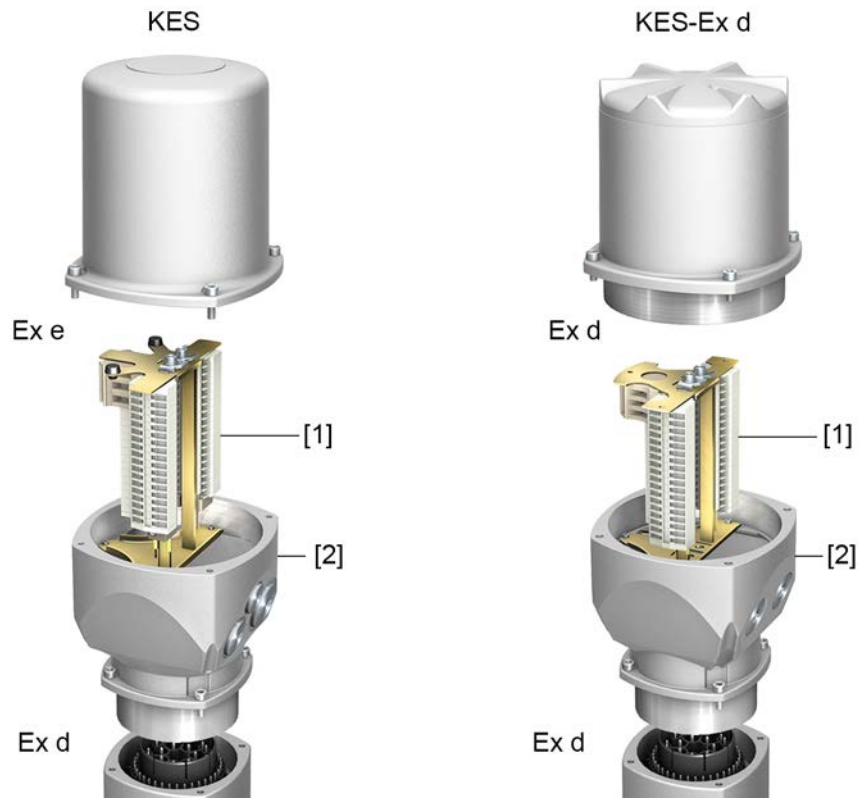

- [1] Terminal blocks
- [2] Connection frame

Short description KES plug-in electrical connection with terminal blocks for power and control contacts. Cable entry via the connection frame. Cover in KES-e version for terminal compartment in type of protection Ex e (increased safety). Cover in KES-Ex d version for terminal compartment in type of protection Ex d (flameproof enclosure).

Plug-in connection is made via the connection frame. For cable connection, simply remove the cover. The connection frame remains within the device. The flameproof interior of the connected devices remains sealed.

Technical data

Table 20:

KES electrical connection		
	Power contacts	Control contacts
No. of contacts max.	3 + protective earth connection at frame	50
Designation	U, V, W, ⊕ (PE)	1 to 50
Connection voltage max.	750 V	250 V
Rated current max.	25 A	10 A
Type of customer connection	Screw connection PE = Ring lug/U-bracket	Cage clamp, screw-type connection as an option
Connection diameter max.	6 mm ² /10 mm ²	2.5 mm ² flexible, 4 mm ² solid

6.5.1. Terminal compartment: open

Figure 42: Open terminal compartment

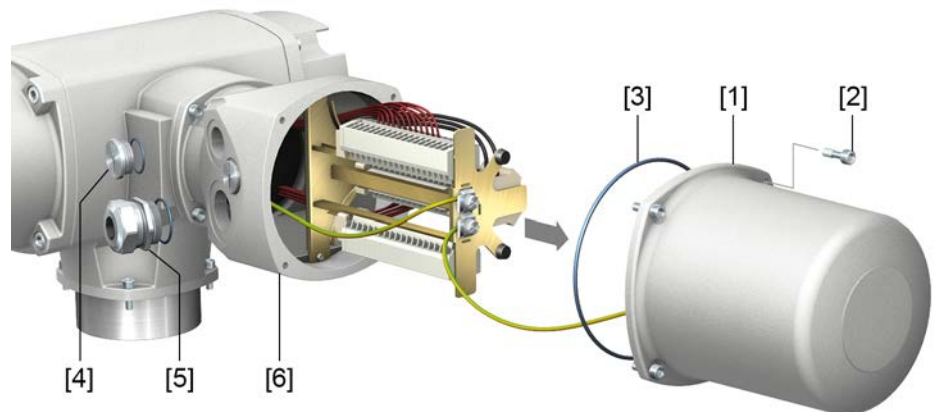

- [1] Cover (illustration shows type of protection Ex e)
- [2] Screws for cover
- [3] O-ring
- [4] Blanking plugs
- [5] Cable gland (example)
- [6] Connection frame



Electric shock due to presence of hazardous voltage!

Failure to observe this warning results in death or serious injury.

- Disconnect device from the mains before opening.
- Wait for 30 seconds after power cut-off prior to opening the housing.

1. Loosen screws [2] and remove cover [1].

Information: Terminal compartment is designed either in type of protection Ex e (increased safety) or in type of protection Ex d (flameproof enclosure) (refer to Ex marking on name plate). The flameproof interior of the connected device remains closed when removing the cover [1].

2. Insert cable glands suitable for connecting cables.

Information: When selecting cable glands observe type of protection (with Ex e or Ex d approval) and enclosure protection IP (refer to name plate). The type of protection stated on the name plate IP is only ensured if suitable cable glands are used.

Figure 43: Name plate, example with enclosure protection IP68



Information: For shielded cables: Use EMC cable glands.

3. Seal unused cable entries with approved plugs suitable for the required protection type.

6.5.2. Cable connection

Table 21:

Terminal cross sections and terminal tightening torques		
Designation	Terminal cross sections	Tightening torques
Power contacts (U, V, W)	max. 10 mm ² (flexible or solid)	1.5 – 1.8 Nm
PE connection	max. 10 mm ² (flexible or solid)	3.0 – 4.0 Nm
Control contacts (1 to 50)	max. 2.5 mm ² flexible, or max. 4 mm ² solid	0.6 – 0.8 Nm

1. Remove cable sheathing and insert the wires into the cable glands.
2. Fasten cable glands with the specified torque to ensure required enclosure protection.
Information: For shielded cables: Link the cable shield end via the cable gland to the housing (earthing).
3. Strip wires.
4. For flexible cables: Use end sleeves according to DIN 46228.
5. Connect cables according to order-related wiring diagram.



In case of a fault: Hazardous voltage while protective earth conductor is NOT connected!

Risk of electric shock.

- Connect all protective earth conductors.
- Connect PE connection to external protective earth conductor of connecting cables.
- Start running the device only after having connected the protective earth conductor.

6. Firmly tighten protective earth to PE connection (symbol: ⊕).

Figure 44: Protective earth (PE)

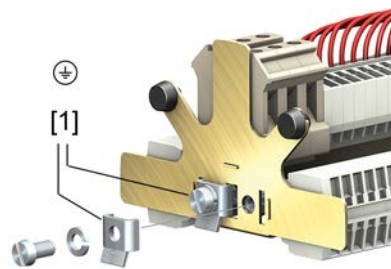

[1] U-bracket for PE connection

6.5.3. Fieldbus cables: connect

Figure 45: Terminal assignment for line topology (1-channel or 2-channel for AUMA redundancy I or II)

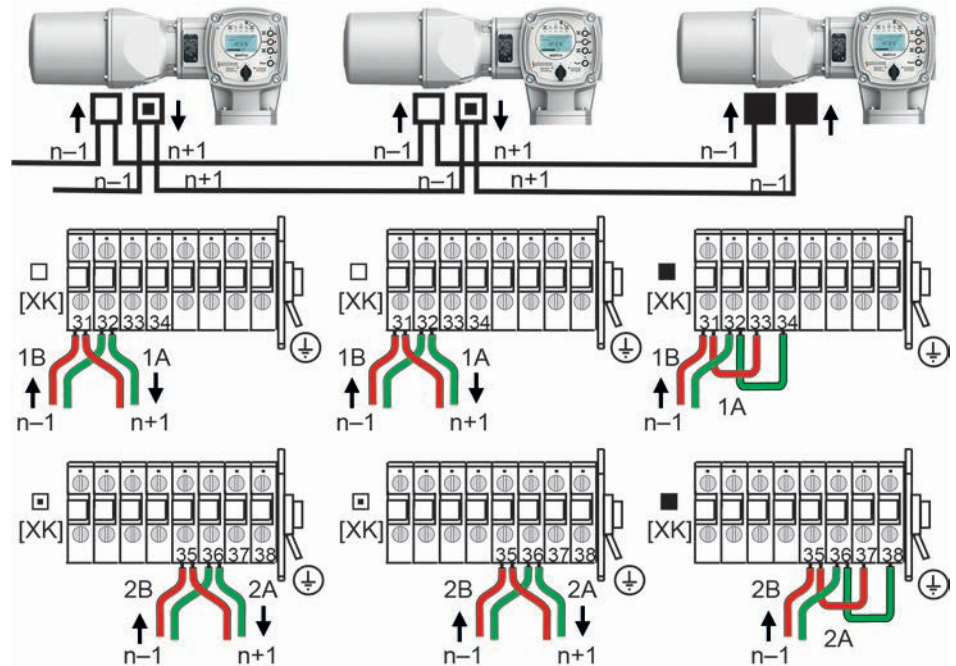

- Channel 1: Further fieldbus devices will follow (standard)
 - ▣ Channel 2: Further fieldbus devices will follow (AUMA redundancy I or II only)
 - Last fieldbus device
- n-1 Fieldbus cable from previous device (input)
 n+1 Fieldbus cable to next device (output)
 [XK] Terminal assignment according to wiring diagram (customer connection):
 Channel 1: Terminals 31, 32 and 33, 34
 Channel 2: Terminals 35, 36 and 37, 38 (AUMA redundancy I or II)

Connect fieldbus cables:

1. Connect bus cables.
 - Always link A connections to green wire and B connections to red wire.
2. If the actuator is the final device in the fieldbus segment (line topology only):
 - 2.1 Connect termination resistor for channel 1 through linking the terminals 31 - 33 and 32 - 34 (standard)
 - 2.2 For AUMA redundancy I or II: Connect termination resistor for channel 2 through linking the terminals 35 - 37 and 36 - 38.

6.5.4. Terminal compartment: close

Figure 46: Close terminal compartment

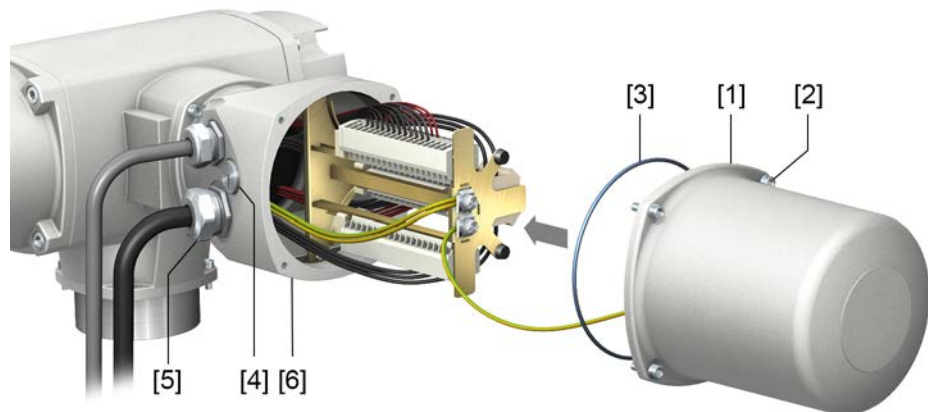

- [1] Cover (illustration shows type of protection Ex e)
- [2] Screws for cover
- [3] O-ring
- [4] Blanking plugs
- [5] Cable gland (example)
- [6] Connection frame

1. Clean sealing faces of cover [1] and connection frame [6].
2. For Ex plug/socket connector designed as KES flameproof: Preserve joint surfaces with an acid-free corrosion protection agent.
3. Check whether O-ring [3] is in good condition, replace if damaged.
4. Apply a thin film of non-acidic grease to the O-ring and insert it correctly.



Flameproof enclosure, danger of explosion!

Risk of death or serious injury.

- Handle cover and housing parts with care.
- Joint surfaces must not be damaged or soiled in any way.
- Do not jam cover during fitting.

5. Fit cover [1] and fasten screws [2] evenly crosswise.

6.6. External earth connection

Figure 47: Earth connection for multi-turn actuator



Figure 48: Earth connection for wall bracket



Application External earth connection (U-bracket) for connection to equipotential compensation.

Table 22:

Terminal cross sections and earth connection tightening torques		
Conductor type	Terminal cross sections	Tightening torques
Solid wire and stranded	2.5 mm ² to 6 mm ²	3 – 4 Nm
Fine stranded	1.5 mm ² to 4 mm ²	3 – 4 Nm

For fine stranded (flexible) wires, connection is made via cable lugs/ring terminals. When connecting two individual wires with a U-bracket, cross sections have to be identical.

6.7. Accessories for electrical connection

6.7.1. Actuator controls on wall bracket

Design principle Figure 49: Design principle with wall bracket (example)

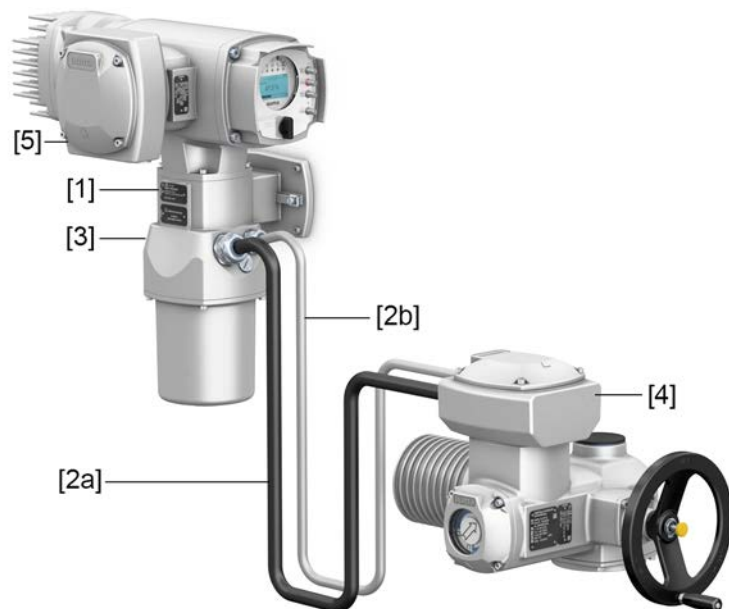

- [1] Wall bracket
- [2a] Motor connection/motor control
- [2b] Feedback signals from actuator
- [3] Electrical connection of wall bracket
- [4] Electrical connection of actuator (XA)
- [5] Electrical connection of actuator controls (XK)

Application The wall bracket allows separate mounting of actuator controls and actuator.

- If the actuator cannot be accessed safely.
- If the actuator is subjected to high temperatures.
- In case of heavy vibration of the valve.

Information on installation with wall bracket

- The permissible cable length between separate local controls and the actuator amounts to 16 m maximum. Longer cables require an external filter (available on request)
- We recommend using an AUMA “LSW” cable set.

6.7.2. Parking frame

Figure 50: PAFEx 01.1 parking frame



Application

Parking frame for safe storage of a disconnected plug or cover.

For protection against touching the bare contacts and against environmental influences.



Explosion hazard!

Risk of death or serious injury.

- Prior to opening the device (removing the plug) ensure that the device is free of gas and voltage!
- Do NOT switch on voltage in potentially explosive atmospheres.

For PAFEx 01.1, separate operation instructions are available.

7. Operation

7.1. Manual operation

For purposes of setting and commissioning, in case of motor or power failure, the actuator may be operated manually. Manual operation is engaged by an internal change-over mechanism.

Manual operation is automatically disengaged when motor is started again. The handwheel does not rotate during motor operation.

7.1.1. Manual valve operation



Damage at the manual change-over mechanism/motor coupling due to faulty operation!

- Engage manual operation only during motor standstill.
- Do NOT use extensions as lever for operation.

Procedure

1. Press push button.
2. Turn handwheel in desired direction.

Figure 51:



➔ The closing direction is marked on the handwheel.

Table 23: Handwheel marking (examples)

→ For valve closing, turn handwheel in direction of the arrowhead.	
 clockwise closing	 counterclockwise closing
Drive shaft (valve) turns clockwise in direction CLOSE.	Drive shaft (valve) turns counterclockwise in direction CLOSE.

Overload protection for manual operation

To protect the valve, an overload protection is available as option for manual operation. If the torque applied at the handwheel exceeds a certain value (refer to order-related technical data sheet), the shear pins will rupture and thus protect the valve from damage. The handwheel can no longer transmit the torque (= handwheel is spinning). Motor operation is still possible. In case of shear pin rupture due to overload, imperatively replace the safety hub.

Figure 52: Handwheel without/with overload protection



- [1] Handwheel without overload protection (standard)
- [2] Handwheel with overload protection/safety hub (option)

7.2. Motor operation

NOTICE

Valve damage due to incorrect basic setting!

→ Prior to electric actuator operation, perform the basic settings for “type of seating” and “torque switching”.

7.2.1. Operating the actuator from local controls

Local actuator operation is performed using the local controls push buttons of actuator controls.

Figure 53: Local controls



- [1] Push button for operation command in direction OPEN
- [2] Push button STOP
- [3] Push button for operation command in direction CLOSE
- [4] Push button RESET
- [5] Selector switch



Hot surfaces, e.g. possibly caused by high ambient temperatures or strong direct sunlight!

Risk of burns

→ Verify surface temperature and wear protective gloves.

→ Set selector switch [5] to position **Local control** (LOCAL).

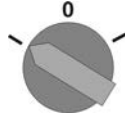

➔ The actuator can now be operated using the push buttons [1 – 3]:

- Run actuator in direction OPEN: Press push button [1]
- Stop actuator: Press push button STOP [2].
- Run actuator in direction CLOSE: Press push button [3]

Information

The OPEN and CLOSE operation commands can be given either in push-to-run or in self-retaining operation mode. In self-retaining mode, the actuator runs to the defined end position after pressing the button, unless another command has been received beforehand. For further information, please refer to the Manual (Operation and setting).

7.2.2. Actuator operation from remote



Risk of immediate actuator operation when switching on!

Risk of personal injuries or damage to the valve

→ If the actuator starts unexpectedly: Immediately turn selector switch to **0** (OFF).

→ Check input signals and functions.

→ Set selector switch to position **Remote control** (REMOTE).

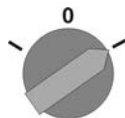

➔ Now, the actuator can be remote-controlled via fieldbus.

Information

For actuators equipped with a positioner, it is possible to change over between **OPEN - CLOSE control** (Remote OPEN-CLOSE) and **setpoint control** (Remote SET-POINT). For further information, please refer to the Manual (Operation and setting).

7.3. Menu navigation via push buttons (for settings and indications)

Menu navigation for display and setting is made via the push buttons [1 – 4] of the local controls.

Set the selector switch [5] to position **0** (OFF) when navigating through the menu.

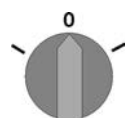

The bottom row of the display [6] serves as navigation support and explains which push buttons [1 – 4] are used for menu navigation.

Figure 54:

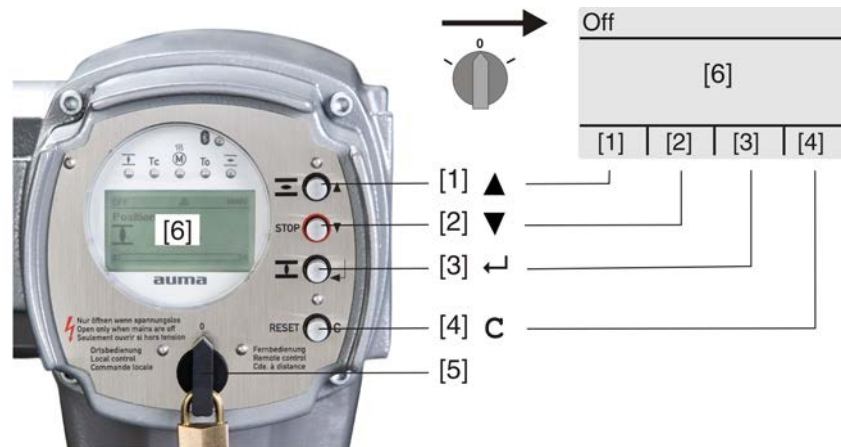

- [1–4] Push buttons or navigation support
- [5] Selector switch
- [6] Display

Table 24: Important push button functions for menu navigation

Push buttons	Navigation support on display	Functions
[1] ▲	Up ▲	Change screen/selection Change values Enter figures from 0 to 9
[2] ▼	Down ▼	Change screen/selection Change values Enter figures from 0 to 9
[3] ←	Ok	Confirm selection
	Save	Save
	Edit	Enter <Edit> menu
	Details	Display more details
[4] C	Setup	Enter Main menu
	Esc	Cancel process
		Return to previous display

- Backlight**
- The display is illuminated in white during normal operation. It is illuminated in red in case of a fault.
 - The screen illumination is brighter when operating a push button. If no push button is operated for 60 seconds, the display will become dim again.

7.3.1. Menu layout and navigation

Groups The indications on the display are divided into 3 groups:

Figure 55: Groups



- [1] Start menu
- [2] Status menu
- [3] Main menu

ID Status menu and main menu are marked with an ID.

Figure 56: Marking with ID



S ID starts with S = status menu
 M ID starts with M = main menu

Group selection

It is possible to select between status menu **S** and main menu **M**:

For this, set selector switch to **0** (OFF), hold down push button **C** for approx. 2 seconds until a screen containing the ID **M...** appears.

Figure 57: Select menu groups

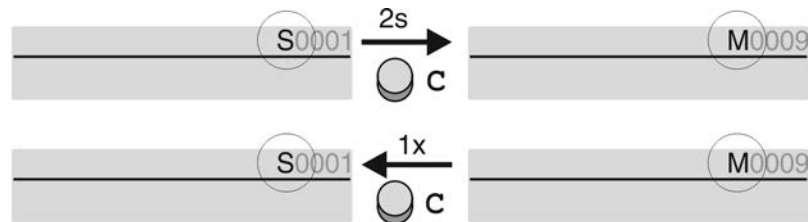

You return to the status menu if:

- the push buttons on the local controls have not been operated within 10 minutes
- or by briefly pressing **C**

Direct display via ID

When entering the ID within the main menu, screens can be displayed directly (without clicking through).

Figure 58: Direct display (example)

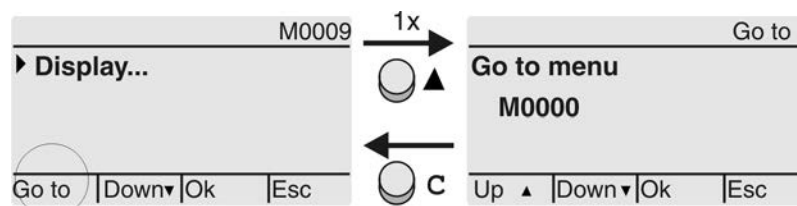

Display indicates in the bottom row: **Go to**

1. Press push button **▲ Go to**.
 Display indicates: **Go to menu M0000**
2. Use push buttons **▲▼ Up ▲ Down ▼** to select figures 0 to 9.
3. Press push button **◀ Ok** to confirm first digit.
4. Repeat steps 2 and 3 for all further digits.
5. To cancel the process: Press **C Esc**.

7.4. User level, password

User level The user level defines which menu items or parameters can be displayed or modified by the active user.

There are 6 different user levels. The user level is indicated in the top row:

Figure 59: User level display (example)

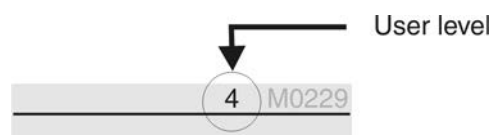

Password A password must be entered to allow parameter modification. The display indicates: **Password 0*****

A specific password is assigned to each user level and permits different actions.

Table 25:

User levels and authorisations	
Designation (user level)	Authorisation/password
Observer (1)	Verify settings No password required
Operator (2)	Change settings Default factory password: 0000
Maintenance (3)	Reserved for future extensions
Specialist (4)	Change device configuration e.g. type of seating, assignment of output contacts Default factory password: 0000
Service (5)	Service staff Change configuration settings
AUMA (6)	AUMA administrator



Unauthorised access is made easier due to insecure password!

→ We urgently recommend changing the password during initial commissioning.

7.4.1. Password entry

- Select desired menu and hold down push button for approx. 3 seconds.
 - ➔ Display indicates the set user level, e.g. **Observer (1)**
- Select higher user level via **▲ Up ▲** and confirm with **OK**.
 - ➔ Display indicates: **Password 0*****
- Use push buttons **▲▼ Up ▲ Down ▼** to select figures 0 to 9.
- Confirm first digit of password via push button **OK**.
- Repeat steps 1 and 2 for all further digits.
 - ➔ Having confirmed the last digit with **OK**, access to all parameters within one user level is possible if the password entry is correct.

7.4.2. Password change

Only the passwords of same or lower access level may be changed.

Example: If the user is signed in as **Specialist (4)**, he/she can change passwords as for password levels (1) through (4).

- M ▶
- Device configuration M0053**
 - Service functions M0222**
 - Change passwords M0229**

Menu item **Service functions M0222** is only visible, if user level **Specialist (4)** or higher is selected.

Select main menu

- Set selector switch to position **0** (OFF).

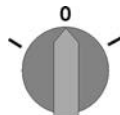

- Press push button **C Setup** and hold it down for approx. 3 seconds.
 - ➔ Display goes to main menu and indicates: ▶ **Display**

- Change passwords**
3. Select parameter **Change passwords** either:
 - click via the menu **M ▷** to parameter, or
 - via direct display: press **▲** and enter ID **M0229**
 - Display indicates: **▶ Change passwords**
 - The user level is indicated in the top row (1 – 6), e.g.:

 - For user level 1 (view only), passwords cannot be changed. To change passwords, you must change to a higher user level. For this, enter a password via a parameter.
 4. For a user level between 2 and 6: Press push button **↵ Ok**.
 - ➔ The display indicates the highest user level, e.g.: **For user 4**
 5. Select user level via push buttons **▲▼ Up ▲ Down ▼** and confirm with **↵ Ok**.
 - ➔ Display indicates: **▶ Change passwords Password 0*****
 6. Enter current password (→ enter password).
 - ➔ Display indicates: **▶ Change passwords Password (new) 0*****
 7. Enter new password (→ enter password).
 - ➔ Display indicates: **▶ Change passwords For user 4 (example)**
 8. Select next user level via push buttons **▲▼ Up ▲ Down ▼** or cancel the process via **Esc**.

7.4.3. Timeout for incorrect password entry

A timeout for incorrect password entry is provided with actuator controls. This prevents unauthorised access by systematic trials. The timeout is active for incorrect entries via the local controls as well as incorrect entries via our software tools (AUMA CDT, AUMA Assistant App). After five subsequent incorrect trials, further entry is inhibited for one minute. Each further incorrect entry doubles the timeout period. An active timeout is displayed on the screen. An individual timeout is available for each user level. This means that you may still log on with user level 3 if user level 4 is inhibited.

The incorrect entry counter can be reset in two ways:

1. Correct password entry with successful access authorisation.
2. 8 hours after the last incorrect entry.

7.5. Language in the display

The display language can be selected.

7.5.1. Language change

M ▷ **Display M0009**
Language M0049

- Select main menu**
1. Set selector switch to position **0** (OFF).

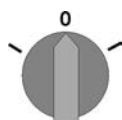

Change language

2. Press push button **C Setup** and hold it down for approx. 3 seconds.
 - ➔ Display goes to main menu and indicates: **▶ Display**
3. Press **↵ Ok**.
 - ➔ Display indicates: **▶ Language**
4. Press **↵ Ok**.
 - ➔ Display indicates the selected language, e.g.: **▶ Deutsch**

5. The bottom row of the display indicates:
 - **Save** → continue with step 10
 - **Edit** → continue with step 6
6. Press **← Edit**.
 - ➔ Display indicates: **▶ Observer (1)**
7. Select user level via **▲▼ Up ▲ Down ▼** resulting in the following significations:
 - black triangle: **▶** = current setting
 - white triangle: **▷** = selection (not saved yet)
8. Press **← Ok**.
 - ➔ Display indicates: **Password 0*****
9. Enter password (→ enter password).
 - ➔ Display indicates: **▶ Language** and **Save** (bottom row)
- Language selection** 10. Select new language via **▲▼ Up ▲ Down ▼** resulting in the following significations:
 - black triangle: **▶** = current setting
 - white triangle: **▷** = selection (not saved yet)
11. Confirm selection via **← Save**.
 - ➔ The display changes to the new language. The new language selection is saved.

8. Indications

8.1. Indications during commissioning

LED test When switching on the power supply, all LEDs on the local controls illuminate for approx. 1 second. This optical feedback indicates that the voltage supply is connected to the controls and all LEDs are operable.

Figure 60: LED test

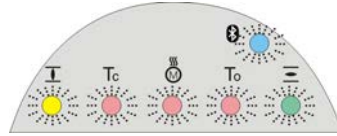

Language selection During the self-test, the language selection can be activated so that the selected language is immediately indicated in the display. For this, set selector switch to position **0** (OFF).

Activate language selection:

1. Display indicates in the bottom line: **Language selection menu? 'Reset'**
2. Hold down push button **RESET** until display of the following text in the bottom line: **Language menu loading, please wait.**

Figure 61: Self-test

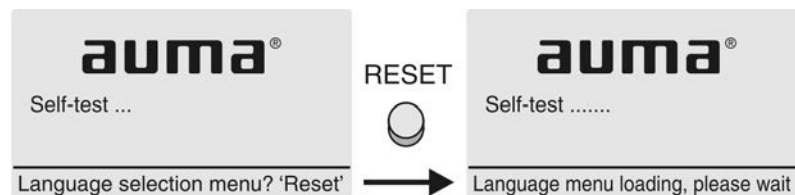

The language selection menu follows the startup menu.

Startup menu The current firmware version is displayed during the startup procedure:

Figure 62: Startup menu with firmware version: 05.00.00–xxxx

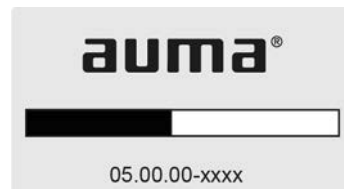

If the language selection feature has been activated during the self-test, the menu for selecting the display language will now be indicated. For further information on language setting, please refer to chapter <Language in the display>.

Figure 63: Language selection

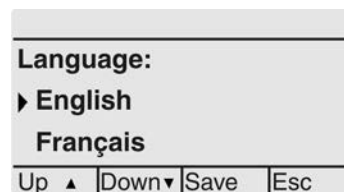

If no entry is made over a longer period of time (approx. 1 minute), the display automatically returns to the first status indication.

8.2. Indications in the display



Menus and functions depend on the actuator controls firmware version!

→ Should menus or functions be unavailable, please contact the AUMA Service.

Status bar The status bar (first row in the display) indicates the operation mode [1], the presence of an error [2] and the ID number [3] of the current display indication.

Figure 64: Information in the status bar (top)

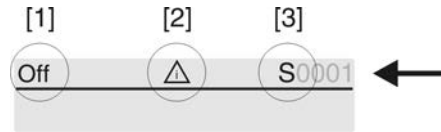

- [1] Operation mode
- [2] Error symbol (only for faults and warnings)
- [3] ID number: S = Status page

Navigation support If further details or information are available with reference to the display, the following indications **Details** or **More** appear in the navigation support (bottom display row). Then, further information can be displayed via the ← push button.

Figure 65: Navigation support (bottom)

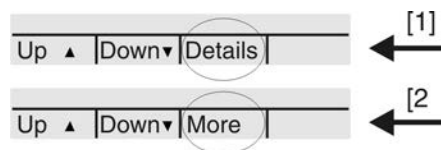

- [1] shows list with detailed indications
- [2] shows further available information

The navigation support (bottom row) is faded out after approx. 3 seconds. Press any push button (selector switch in position 0 (OFF)) to fade in the navigation support.

8.2.1. Feedback signals from actuator and valve

Display indications depend on the actuator version.

Valve position (S0001)

- S0001 on the display indicates the valve position in % of the travel.
- The bar graph display appears after approx. 3 seconds.
- When issuing an operation command, an arrow indicates the direction (OPEN/CLOSE).

Figure 66: Valve position and direction of operation

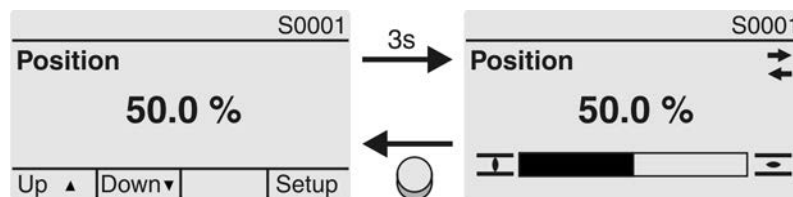

Reaching the preset end positions is additionally indicated via (CLOSED) and (OPEN) symbols.

Figure 67: End position CLOSED/OPEN reached

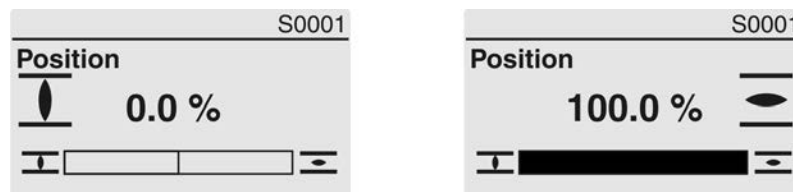

- 0% Actuator is in end position CLOSED
- 100% Actuator is in end position OPEN

Torque (S0002)

- S0002 on the display indicates the torque applied at the actuator output.

- The bar graph display appears after approx. 3 seconds.

Figure 68: Torque

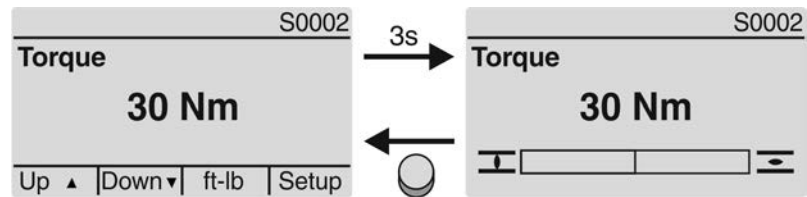

Select unit

The push button allows to select the unit displayed (percent %, Newton metre Nm or "foot-pound" ft-lb)

Figure 69: Units of torque

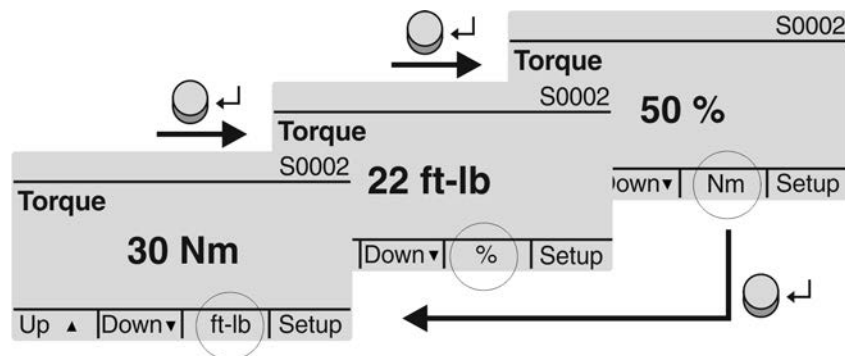

Display in percent

100 % indication equals the max. torque indicated on the name plate of the actuator.

Example: Torque range on name plate = 20 – 60 Nm.

- 100 % corresponds to 60 Nm of nominal torque.
- 50 % corresponds to 30 Nm of nominal torque.

Operation commands (S0003)

The display S0003 indicates:

- active operation commands, like e.g.: Operation in direction CLOSE or in direction OPEN
- the actual value E2 as bar graph indication and as value between 0 and 100 %.
- for setpoint control (positioner): setpoint E1
- for stepping mode or for intermediate positions with operation profile: pivot points and operation behaviour of pivot points

The navigation support (bottom row) is faded out after approx. 3 seconds and the axis/axes for pivot point display are shown.

OPEN - CLOSE control

Active operation commands (OPEN, CLOSE, ...) are shown above the bar graph display. The figure below shows the operation command in direction CLOSE.

Figure 70: Display for OPEN - CLOSE control

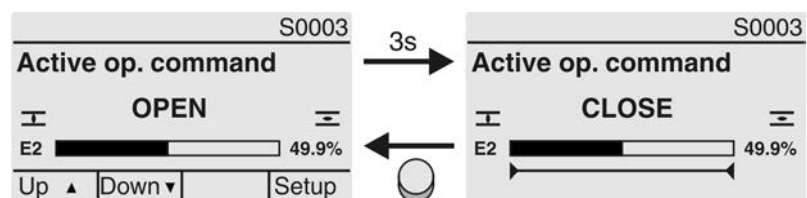

E2 Actual position value

Setpoint control

If the positioner is enabled and activated, the bar graph indication for E1 (position setpoint) is displayed.

The direction of the operation command is displayed by an arrow above the bar graph indication. The figure below shows the operation command in direction CLOSE.

Figure 71: Indication for setpoint control (positioner)

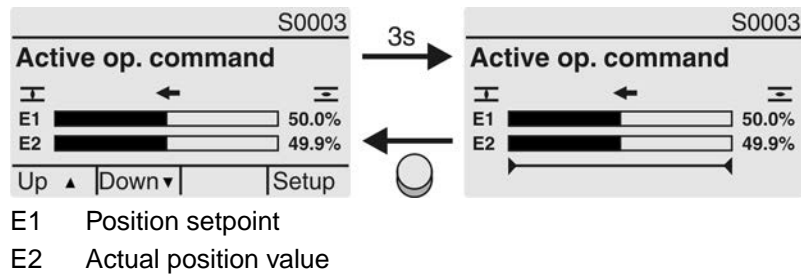

Pivot point axis

The pivot points and their operation behaviour (operation profile) are shown on the pivot point axis by means of symbols.

The symbols are only displayed if at least one of the following functions is activated:

Operation profile M0294

Timer CLOSE M0156

Timer OPEN M0206

Figure 72: Examples: on the left pivot points (intermediate positions); on the right stepping mode

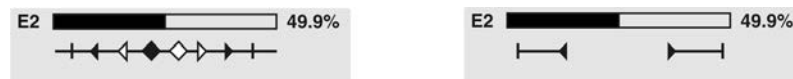

Table 26: Symbols along the pivot point axis

Symbol	Pivot point (intermediate position) with operation profile	Stepping mode
	Pivot point without reaction	End of stepping mode
◀	Stop during operation in direction CLOSE	Start of stepping mode in direction CLOSE
▶	Stop during operation in direction OPEN	Start of stepping mode in direction OPEN
◆	Stop during operation in directions OPEN and CLOSE	–
◁	Pause for operation in direction CLOSE	–
▷	Pause for operation in direction OPEN	–
◇	Pause for operation in directions OPEN and CLOSE	–

8.2.2. Status indications according to AUMA classification

These indications are available if the parameter **Diagnostic classific. M0539** is set to **AUMA**.

Warnings (S0005)

If a warning has occurred, the display shows **S0005**:

- the number of warnings occurred
- a blinking question mark after approx. 3 seconds

Figure 73: Warnings

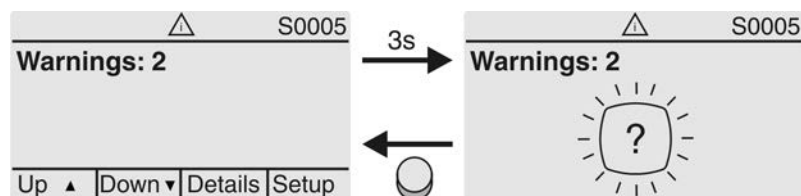

For further information, please also refer to <Corrective action>.

Not ready REMOTE (S0006)

The S0006 display shows indications of the Not ready REMOTE group.

If such an indication has occurred, the display shows S0006:

- the number of indications occurred
- a blinking crossbar after approx. 3 seconds

Figure 74: Not ready REMOTE indications

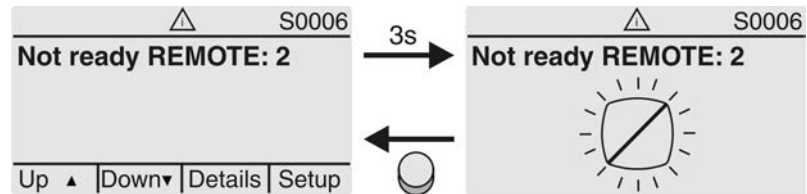

For further information, please also refer to <Corrective action>.

Fault (S0007)

If a fault has occurred, the display shows S0007:

- the number of faults occurred
- a blinking exclamation mark after approx. 3 seconds

Figure 75: Fault

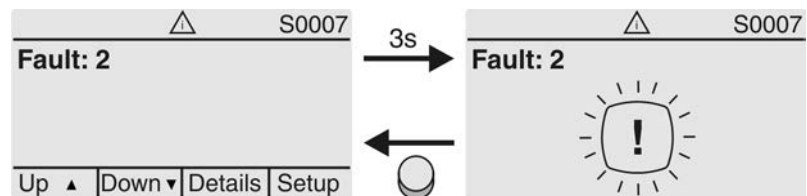

For further information, please also refer to <Corrective action>.

8.2.3. Status indications according to NAMUR recommendation

These indications are available, if the parameter **Diagnostic classific. M0539** is set to **NAMUR**.

Out of Specification (S0008)

The S0008 indication shows out of specification indications according to NAMUR recommendation NE 107.

If such an indication has occurred, the display shows S0008:

- the number of indications occurred
- a blinking triangle with question mark after approx. 3 seconds

Figure 76: Out of specification

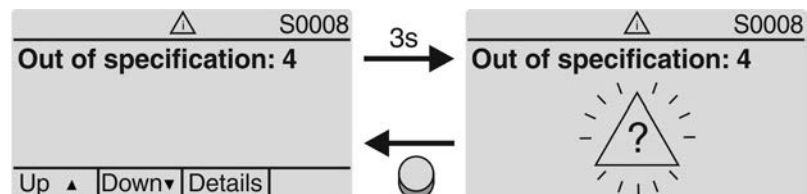

For further information, please also refer to <Corrective action>.

Function check (S0009)

The S0009 indication shows function check indications according to NAMUR recommendation NE 107.

If an indication has occurred via the function check, the display shows S0009:

- the number of indications occurred
- a blinking triangle with a spanner after approx. 3 seconds

Figure 77: Function check

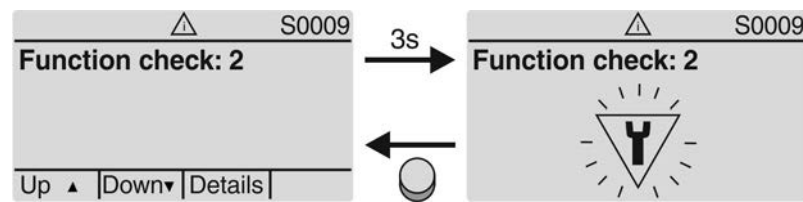

For further information, please also refer to <Corrective action>.

Maintenance required (S0010)

The **S0010** indication shows maintenance indications according to NAMUR recommendation NE 107.

If such an indication has occurred, the display shows **S0010**:

- the number of indications occurred
- a blinking square with an oilcan after approx. 3 seconds

Figure 78: Maintenance required

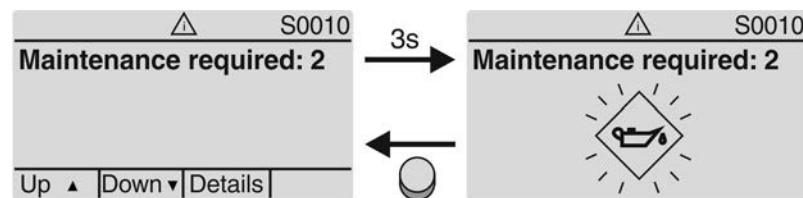

For further information, please also refer to <Corrective action>.

Failure (S0011)

The **S0011** indication shows the causes of the failure indication according to NAMUR recommendation NE 107.

If such an indication has occurred, the display shows **S0011**:

- the number of indications occurred
- a blinking circle with a cross after approx. 3 seconds

Figure 79: Failure

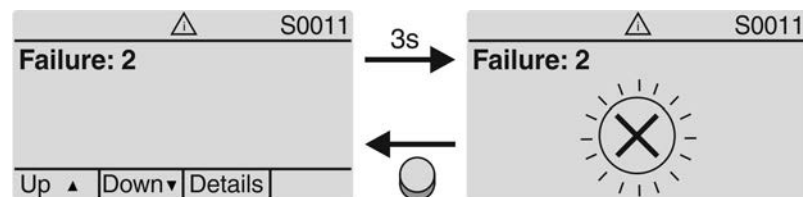

For further information, please also refer to <Corrective action>.

8.3. Indication lights of local controls

Figure 80: Arrangement and signification of indication lights



- [1] Marking with symbols (standard)
- [2] Marking with figures 1 – 6 (option)
- 1 End position CLOSED reached (blinking: operation in direction CLOSE)
- 2 Tc Torque fault CLOSE
- 3 Motor protection tripped
- 4 To Torque fault OPEN
- 5 End position OPEN reached (blinking: operation in direction OPEN)
- 6 Bluetooth connection active

Modify indication light assignment (indications)

Different indications can be assigned to LEDs 1 – 5.

- M ▷ **Device configuration M0053**
- Local controls M0159**
- Indication light 1 (left) M0093**
- Indication light 2 M0094**
- Indication light 3 M0095**
- Indication light 4 M0096**
- Indicat. light 5 (right) M0097**
- Signal interm. pos. M0167**

Default values (Europe):

- Indication light 1 (left) = End p. CLOSED, blink
- Indication light 2 = Torque fault CLOSE
- Indication light 3 = Thermal fault
- Indication light 4 = Torque fault OPEN
- Indicat. light 5 (right) = End p. OPEN, blink
- Signal interm. pos. = OPEN/CLOSED = Off

Further setting values:

Refer to Manual (Operation and setting).

8.4. Optional indications

8.4.1. Mechanical position indication via indicator mark (not self-adjusting)

Figure 81: Mechanical position indicator



- [1] End position OPEN reached
- [2] End position CLOSED reached
- [3] Indicator mark at cover

Characteristics

- Independent of power supply
- Used as running indication: Indicator disc rotates during actuator operation and continuously indicates the valve position
 (For “clockwise closing” version, the symbols $\overline{\text{H}}$ / $\underline{\text{H}}$ rotate in counterclockwise direction for operations in direction CLOSE)
- Indicates that end positions (OPEN/CLOSED) have been reached
 (Symbols $\overline{\text{H}}$ (OPEN)/ $\underline{\text{H}}$ (CLOSED) point to the indicator mark \blacktriangle at cover)

8.4.2. Mechanical position indication (self-adjusting)

Figure 82: Mechanical position indicator



- [1] End position OPEN reached
- [2] End position CLOSED reached

Characteristics

- Independent of power supply
- Used as running indication: Indicator disc (with arrow \rightleftarrows) rotates during actuator operation and continuously indicates the valve position
 (For “clockwise closing version”, the arrow rotates in clockwise direction for operation in direction CLOSE)
- Indicates that end positions (OPEN/CLOSED) have been reached
 Arrow \rightleftarrows points to symbol $\overline{\text{H}}$ (OPEN) or $\underline{\text{H}}$ (CLOSED)
- Self-adjusting during commissioning (cover must not be opened)

9. Signals (output signals)

9.1. Signals via fieldbus

Feedback signals via fieldbus can be configured. Configuration is possible for both data structure and data contents.

Configuration is defined via the GSD file only.

Information If required, download the GSD file (General Station Description) from the Internet: www.auma.com

For information on the feedback signals via fieldbus and the configuration of the parameters via fieldbus interface, refer to Manual (Device integration fieldbus) Profibus DP.

9.2. Status signals via output contacts (digital outputs)

Conditions Output contacts are only available if a parallel interface is provided in addition to the fieldbus interface.

Characteristics Output contacts are used to send status signals (e.g. reaching the end positions, selector switch position, faults...) as binary signals to the control room.

Status signals only have two states: active or inactive. Active means that the conditions for the signal are fulfilled.

9.2.1. Assignment of outputs

The output contacts (outputs DOUT 1 – 6) can be assigned to various signals.

Required user level: **Specialist (4)** or higher.

M ▷ **Device configuration M0053**
 I/O interface M0139
 Digital outputs M0110
 Signal DOUT 1 M0109

Default values:

Signal DOUT 1 = **Fault**
Signal DOUT 2 = **End position CLOSED**
Signal DOUT 3 = **End position OPEN**
Signal DOUT 4 = **Selector sw. REMOTE**
Signal DOUT 5 = **Torque fault CLOSE**
Signal DOUT 6 = **Torque fault OPEN**

9.2.2. Coding the outputs

The output signals **Coding DOUT 1** – **Coding DOUT 6** can be set either to high active or low active.

- High active = output contact closed = signal active
- Low active = output contact open = signal active

Signal active means that the conditions for the signal are fulfilled.

Required user level: **Specialist (4)** or higher.

M ▷ **Device configuration M0053**
 I/O interface M0139
 Digital outputs M0110
 Coding DOUT 1 M0102

Default values:

Coding DOUT 1 = **Low active**
Coding DOUT 2–Coding DOUT 6 = **High active**

9.3. Analogue signals (analogue outputs)

- Requirements** Analogue signals are only available if additional input signals are provided.
- Valve position** Signal: E2 = 0/4 – 20 mA (galvanically isolated)
Designation in the wiring diagram: AOUT1 (position)
- Torque feedback** Signal: E6 = 0/4 – 20 mA (galvanically isolated)
Designation in the wiring diagram: AOUT2 (torque)
For further information on this topic, please refer to Manual (Operation and setting).

10. Commissioning (basic settings)

1. Set selector switch to position **0** (OFF).

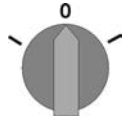

Information: The selector switch is not a mains switch. When positioned to **0** (OFF), the actuator cannot be operated. The controls' power supply is maintained.

2. Switch on the power supply.

Information: Observe heat-up time for ambient temperatures below $-30\text{ }^{\circ}\text{C}$.

3. Perform basic settings.

10.1. Type of seating: set

NOTICE

Valve damage due to incorrect setting!

- The type of seating setting (limit or torque seating) must match the selection for the valve.
- Only change the setting with prior consent of the valve manufacturer.

M ▶ **Customer settings M0041**
Type of seating M0012
End position CLOSED M0086
End position OPEN M0087

Default value: Limit

Setting values:

Limit Seating in end positions via limit switching.

Torque Seating in end positions via torque switching.

- Select main menu**
1. Set selector switch to position **0** (OFF).

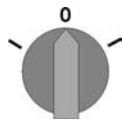

2. Press push button **C Setup** and hold it down for approx. 3 seconds.

➔ Display goes to main menu and indicates: ▶ **Display**

- Select parameter**
3. Select parameter either:

→ click via the menu **M ▶** to parameter, or

→ via direct display: Press **▲** and enter ID **M0086** or **M0087**

➔ Display indicates: **End position CLOSED**

- CLOSE or OPEN**
4. Use **▲ ▼ Up ▲ Down ▼** to select:

→ ▶ **End position CLOSED**

→ ▶ **End position OPEN**

➔ The black triangle ▶ indicates the current selection.

5. Press **↵ Ok**.

➔ Display indicates the current setting: **Limit** or **Torque**

➔ The bottom row of the display indicates either:

- **Edit** → continue with step 6

- **Save** → continue with step 10

- | | |
|------------------------|--|
| User login | <ol style="list-style-type: none"> 6. Press ← Edit. ➔ Display indicates: ▶ Specialist (4) 7. Use ▲▼ Up ▲ Down ▼ to select user:
Information: Required user level: Specialist (4) or higher ➔ The symbols have the following meaning: <ul style="list-style-type: none"> - black triangle: ▶ = current setting - white triangle: ▷ = selection (not saved yet) 8. Press ← Ok. ➔ Display indicates: Password 0*** 9. Enter password (→ enter password). ➔ The screen indicates the pre-set type of seating (▶ Limit or ▶ Torque) by means of a black triangle ▶. |
| Change settings | <ol style="list-style-type: none"> 10. Use ▲▼ Up ▲ Down ▼ to select new setting. ➔ The symbols have the following meaning: <ul style="list-style-type: none"> - black triangle: ▶ = current setting - white triangle: ▷ = selection (not saved yet) 11. Confirm selection via ← Save. ➔ The setting for the type of seating is complete. 12. Back to step 4 (CLOSED or OPEN): Press ← Esc. |

10.2. Torque switching: set

Once the set torque is reached, the torque switches will be tripped (overload protection of the valve).

Information The torque switches may also trip during manual operation.

NOTICE

Valve damage due to excessive tripping torque limit setting!

- The tripping torque must suit the valve.
- Only change the setting with the consent of the valve manufacturer.

M ▶ Customer settings **M0041**
Torque switching **M0013**
Trip torque CLOSE **M0088**
Trip torque OPEN **M0089**

Default value: According to order data

Setting range: Torque range according to actuator name plate

- Select main menu** 1. Set selector switch to position **0** (OFF).

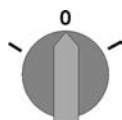

2. Press push button **C Setup** and hold it down for approx. 3 seconds.
➔ Display goes to main menu and indicates: **▶ Display**

Select parameter

3. Select parameter either:
→ click via the menu **M ▶** to parameter, or
→ via direct display: press **▲** and enter ID **M0088**.
➔ Display indicates: **Trip torque CLOSE**

- CLOSE or OPEN**
4. Use ▲▼ Up ▲ Down ▼ to select:
 - ▶ Trip torque CLOSE
 - ▶ Trip torque OPEN
 - ➔ The black triangle ▶ indicates the current selection.
 5. ⏪ Press **Ok**.
 - ➔ Display shows the set value.
 - ➔ The bottom row indicates: **Edit Esc**
 6. ⏪ Press **Edit**.
 - ➔ Display indicates:
 - **Specialist (4)** → continue with step 7
 - in bottom row **Up ▲ Down ▼ Esc** → continue with step 11
- User login**
7. Use ▲▼ Up ▲ Down ▼ to select user:
 - Information:** Required user level: **Specialist (4)** or higher.
 - ➔ The symbols have the following meanings:
 - black triangle: ▶ = current setting
 - white triangle: ▷ = selection (not saved yet)
 8. ⏪ Press **Ok**.
 - ➔ Display indicates: **Password 0*****
 9. Enter password (→ enter password).
 - ➔ Display shows the set value.
 - ➔ The bottom row indicates: **Edit Esc**
 10. ⏪ Press **Edit**.
- Change value**
11. Enter new value for tripping torque via ▲▼ Up ▲ Down ▼.
 - Information:** The adjustable torque range is shown in round brackets.
 12. Save new value via ⏪ **Save**.
 - ➔ The tripping torque is set.
 13. Back to step 4 (CLOSED or OPEN): Press ⏪ **Esc**.
- Information**
- The following fault signals are issued if the torque setting performed has been reached **in mid-travel**:
- In the display of the local controls: Status indication **S0007 Fault = Torque fault OPEN** or **Torque fault CLOSE**
- The fault has to be acknowledged before the operation can be resumed. The acknowledgement is made:
1. either by an operation command in the opposite direction.
 - For **Torque fault OPEN**: Operation command in direction **CLOSE**
 - For **Torque fault CLOSE**: Operation command in direction **OPEN**
 2. or, in case the torque applied is lower than the preset tripping torque:
 - in selector switch position **Local control (LOCAL)** via push button **RESET**.
 - in selector switch position **Remote control (REMOTE)**:
 - via the fieldbus, command reset., if the fieldbus is the active command source.
 - via a digital input (I/O interface) with **RESET** command if a digital input is configured for signal **RESET** and the I/O interface is the active command source.

10.3. Limit switching: set

NOTICE

Valve damage at valve/gearbox due to incorrect setting!

- When setting with motor operation: Stop actuator **prior** to reaching end of travel (press STOP push button).
- For limit seating, provide for sufficient backlash between end position and mechanical end stop due to potential overrun.

- M ▶ Customer settings M0041
Limit switching M0010
Set end pos. CLOSED? M0084
Set end pos. OPEN? M0085

- Select main menu 1. Set selector switch to position 0 (OFF).

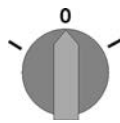

2. Press push button **C** and hold it down for approx. 3 seconds.
➔ Display goes to main menu and indicates: ▶ Display

- Select parameter 3. Select parameter either:
→ click via the menu M ▶ to parameter, or
→ via direct display: press ▲ and enter ID M0084.
➔ Display indicates: Set end pos. CLOSED?

- CLOSED or OPEN 4. Select via ▲ ▼ Up ▲ Down ▼:
→ ▶ Set end pos. CLOSED? M0084
→ ▶ Set end pos. OPEN? M0085
➔ The black triangle ▶ indicates the current selection.
5. Press ◀ Ok.

- User login 6. Use ▲ ▼ Up ▲ Down ▼ to select user:
Information: Required user level: Specialist (4) or higher
➔ The symbols have the following meaning:
- black triangle: ▶ = current setting
- white triangle: ▷ = selection (not saved yet)
7. Press Ok to confirm selected user.
➔ Display indicates: Password 0***

8. Enter password (→ enter password).
➔ The display indicates either:
- Set end pos. CLOSED? CMD0009 → continue with step 9
- Set end pos. OPEN? CMD0010 → continue with step 12

**Set end position
 CLOSED** **CMD0009**

9. Set end position CLOSED again :
 - 9.1 For large strokes: Set selector switch in position **Local control** (LOCAL) and operate actuator in motor operation via push button  (CLOSE) in direction of the end position.
Information: Stop actuator **before** reaching end of travel (press **STOP** push button to avoid damage).
 - 9.2 Engage manual operation.
 - 9.3 Turn handwheel until valve is closed.
 - 9.4 Turn handwheel by approximately half a turn (overrun) in the opposite direction of end position.
 - 9.5 Set selector switch to position **0** (OFF).
 ➔ Display indicates: **Set end pos.CLOSED? Yes No**

Confirm new end position

10. Press  **Yes** to confirm new end position.
 ➔ Display indicates: **End pos. CLOSED set!**
 ➔ The left LED is illuminated (standard version) and thus indicates that the end position CLOSED setting is complete.

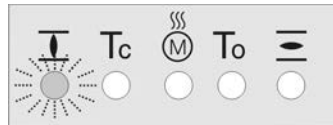

11. Make selection:
 - **Edit** → back to step 9: Set end position CLOSED "once again"
 - **Esc** → back to step 4; either set end position OPEN or exit the menu.

Set end position OPEN **CMD0010**

12. Re-set end position OPEN:
 - 12.1 For large strokes: Set selector switch in position **Local control** (LOCAL) and operate actuator in motor operation via push button  (OPEN) in direction of the end position.
Information: Stop actuator **before** reaching end of travel (press **STOP** push button to avoid damage).
 - 12.2 Engage manual operation.
 - 12.3 Turn handwheel until valve is open.
 - 12.4 Turn handwheel by approximately half a turn (overrun) in the opposite direction of end position.
 - 12.5 Set selector switch to position **0** (OFF).
 ➔ Display indicates: **Set end pos. OPEN? Yes No**

Confirm new end position

13. Press  **Yes** to confirm new end position.
 ➔ Display indicates: **End pos. OPEN set!**
 ➔ The right LED is illuminated (standard version) and thus indicates that the end position OPEN setting is complete.

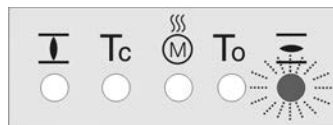

14. Make selection:
 - **Edit** → back to step 12: Set end position OPEN "once again"
 - **Esc** → back to step 4; either set end position CLOSED or exit the menu.

Information If an end position cannot be set: Check the type of control unit in actuator.

10.4. Output speed (internal): set

This setting is only required if an internally specified speed is set as speed source:

- Sp. source... = Internal 1/Internal 2/Internal 3/Internal 4
- Sp. source... = 2 DigIn: "Internal (1-4)"

If the actuator is controlled via an external speed source, the internal speed values described here will not have an impact on the operation behaviour.

For further information on setting the speed source refer to Manual (Operation and Setting):

- M ▷ Customer settings M0041
 - Speed functions M1699
 - Speed internal1 M1930
 - Speed internal2 M1931
 - Speed internal3 M1932
 - Speed internal 4 M1933
 - Speed rem. min. M1936
 - Speed rem. max M1937

Default value: according to order data

Setting range: The adjustable speed range is indicated on the actuator name plate.

- Select main menu** 1. Set selector switch to position **0** (OFF).

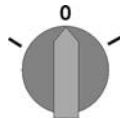

2. Press push button **C Setup** and hold it down for approx. 3 seconds.
 ↳ Display goes to main menu and indicates: ▶ **Display**

- Select parameter** 3. Select parameter either:
 → click via the menu **M ▷** to parameter, or
 → via direct display: Press **▲** and enter ID, e.g.: **M1930**.
 ↳ Display indicates: **Speed internal1**

- Selection:** 4. Select via **▲ ▼ Up ▲ Down ▼**:
 → ▶ **Speed internal1 M1930**
 → ▶ **Speed internal2 M1931**
 → ▶ **Speed internal3 M1932**
 → ▶ **Speed internal 4 M1933**
 → ▶ **Speed rem. min. M1936**
 → ▶ **Speed rem. max M1937**
 ↳ The black triangle ▶ indicates the current selection.
5. Press **↵ Ok**.
 ↳ Display shows the set value.
 ↳ The bottom row indicates: **Edit Esc**
6. Press **↵ Edit**.
 ↳ Display indicates:
 - **Specialist (4)** → continue with step 7
 - in bottom row **Up ▲ Down ▼ Esc** → continue with step 11

- Log on user**
7. Use ▲▼ Up ▲ Down ▼ to select user:
Information: Required user level: Specialist (4) or higher
 - ➔ The symbols have the following meaning:
 - black triangle: ▶ = current setting
 - white triangle: ▷ = selection (not saved yet)
 8. Press ⏏ OK.
 - ➔ Display indicates: Password 0***
 9. Enter password (→ enter password).
 - ➔ Display shows the set value.
 - ➔ The bottom row indicates: Edit Esc
 10. Press ⏏ Edit.
- Change value**
11. Enter new value for speed via ▲▼ Up ▲ Down ▼.
Information: The adjustable speed range is shown in round brackets.
 12. Save new value via ⏏ Save.
 - ➔ Speed setting is complete.
 13. Return to step 4 (Selection): Press ⏏ Esc.

10.5. Fieldbus address (slave address): set

M ▷ Customer settings M0041
 Profibus DP M0016
 DP1 slave address M0098
 DP2 slave address M0295

Default value: 126

Setting range: 0 – 126

Information Parameter DP2 slave address is only available if redundancy (option) is available.

- Select main menu**
1. Set selector switch to position 0 (OFF).

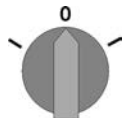

2. Press push button C Setup and hold it down for approx. 3 seconds.
 ➔ Display goes to main menu and indicates: ▶ Display
3. Select parameter either:
 - M ▷ (by clicking through the menu)
 - or press ▲ and enter IDs M0098 or M0295 (direct selection)
 ➔ Display indicates: DP1 slave address
4. Select via ▲▼ Up ▲ Down ▼:
 - ▶ DP1 slave address
 - ▶ DP2 slave address
 ➔ The black triangle ▶ indicates the current selection.
5. Press ⏏ OK.
- ➔ Display shows the set address.
6. The bottom row of the display indicates:
 - Edit → continue with step 7
 - Up ▲ Down ▼ → continue with step 11
7. Press ⏏ Edit.
- ➔ Display indicates: Observer (1)

8. Select access level via ▲▼ Up ▲ Down ▼, resulting in the following significations:
 - black triangle: ▶ = current setting
 - white triangle: ▷ = selection (not saved yet)**Information:** Required access level: Specialist (4) or higher
9. Press ← Ok.
 - ➔ Display indicates: Password 0***
10. Enter password (→ enter password).
 - ➔ Display shows the set address.
11. Enter new address via ▲▼ Up ▲ Down ▼.
 - Information:** The address range is displayed in round brackets on the screen.
12. Confirm selection via ← Save.
 - ➔ The setting for the Profibus address is complete.

10.6. Test run

Only perform test run only once all settings previously described have been performed.

The direction of rotation can be checked at the position indicator if available. (Chapter <Direction of rotation at mechanical position indicator: check>)

The direction of rotation must be checked at the hollow shaft/stem if no mechanical position indicator is available. (Chapter <Direction of rotation at hollow shaft/stem: check>)

10.6.1. Direction of rotation at mechanical position indicator: check

NOTICE

Valve damage due to incorrect direction of rotation!

- If the direction of rotation is wrong, switch off immediately (press STOP).
- Eliminate cause, i.e. correct phase sequence for cable set wall bracket.
- Repeat test run.

Information

Switch off before reaching the end position.

1. Move actuator manually to intermediate position or to sufficient distance from end position.

2. Switch on actuator in direction CLOSE and observe the direction of rotation on the mechanical position indication:

→ **For self-adjusting mechanical position indication:**

- ➔ The direction of rotation is correct if the actuator operates in direction **CLOSE** and arrow \Rightarrow turns **clockwise** in direction CLOSE (symbol $\overline{\text{T}}$).

Figure 83: Direction of rotation \Rightarrow (for “clockwise closing” version”)



→ **For mechanical position indication via indicator mark: (not self-adjusting)**

- ➔ The direction of rotation is correct if the actuator operation in direction **CLOSE** and the symbols $\overline{\text{T}}$ turn **counterclockwise**:

Figure 84: Direction of rotation $\overline{\text{T}}$ (for “clockwise closing version”)



10.6.2. Direction of rotation at hollow shaft/stem: check

Figure 85: Direction of rotation of the hollow shaft/stem for operation in direction CLOSE (“clockwise closing” version)

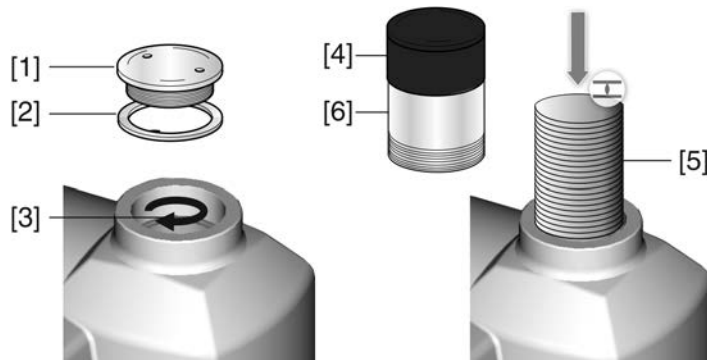

- [1] Threaded plug
- [2] Seal
- [3] Hollow shaft
- [4] Protective cap for stem protection tube
- [5] Stem
- [6] Stem protection tube

NOTICE

Valve damage due to incorrect direction of rotation!

- If the direction of rotation is wrong, switch off immediately (press STOP).
- Eliminate cause, i.e. correct phase sequence for cable set wall bracket.
- Repeat test run.

Check direction of rotation

1. Move actuator manually to intermediate position or to sufficient distance from end position.
2. Depending on the version: Unscrew threaded plug [1] with seal [2], protective cap [4] or stem protection tube [6].
3. Switch on actuator in direction CLOSE and observe direction of rotation at hollow shaft [3] or stem [5]:
 - ➔ The direction of rotation is correct if the actuator moves in direction **CLOSE** and the hollow shaft in **clockwise** direction, or the stem moves downward.
4. Correctly fit/screw on threaded plug [1] with seal [2], protective cap [4] for stem protection tube [6], fasten thread.

10.6.3. Limit switching: check

1. Set selector switch to position **Local control** (LOCAL).

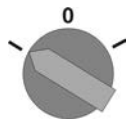

2. Operate actuator using push buttons OPEN, STOP, CLOSE.
 - ➔ The limit switching is set correctly if (default indication):
 - the yellow indication light/LED1 is illuminated in end position CLOSED
 - the green indication light/LED5 is illuminated in end position OPEN
 - the indication lights go out after travelling into opposite direction.
 - ➔ The limit switching is set incorrectly if:
 - the actuator comes to a standstill before reaching the end position
 - one of the red indication lights/LEDs is illuminated (torque fault)
 - the status indication **S0007** in the display signals a fault.
3. If the end position setting is incorrect: Reset limit switching.

11. Commissioning (settings/options in the actuator)

For actuators without mechanical position indicator (cover without indicator glass), no settings are required within the actuator when commissioning.

When equipped with the self-adjusting mechanical position indication [A], the position indication automatically adjusts upon the initial operation (e.g. from CLOSED to OPEN). This self-adjustment is generally performed when setting the limit switches (approaching the end positions). Manual setting and consequently opening the switch compartment is not necessary when commissioning.

In case the mechanical position indicator integrated within the actuator is NOT self-adjusting [B], the switch compartment must be opened for mechanical position indication adjustment when commissioning.

Figure 86: Mechanical position indications

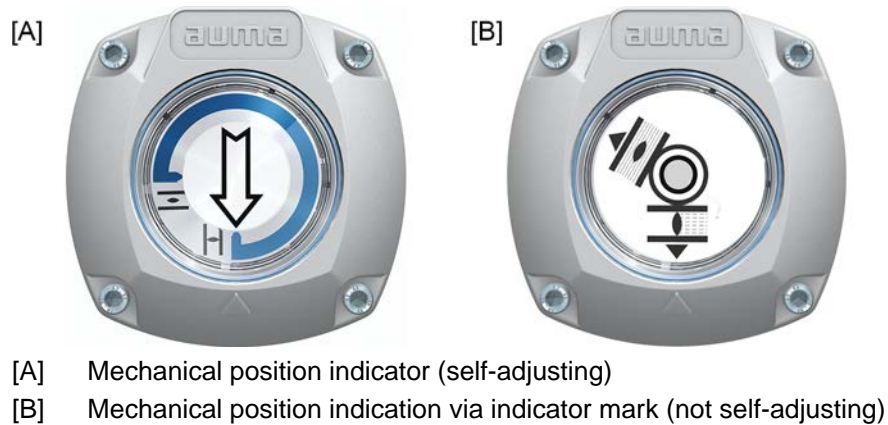

11.1. Switch compartment: open/close

Figure 87: Open/close switch compartment

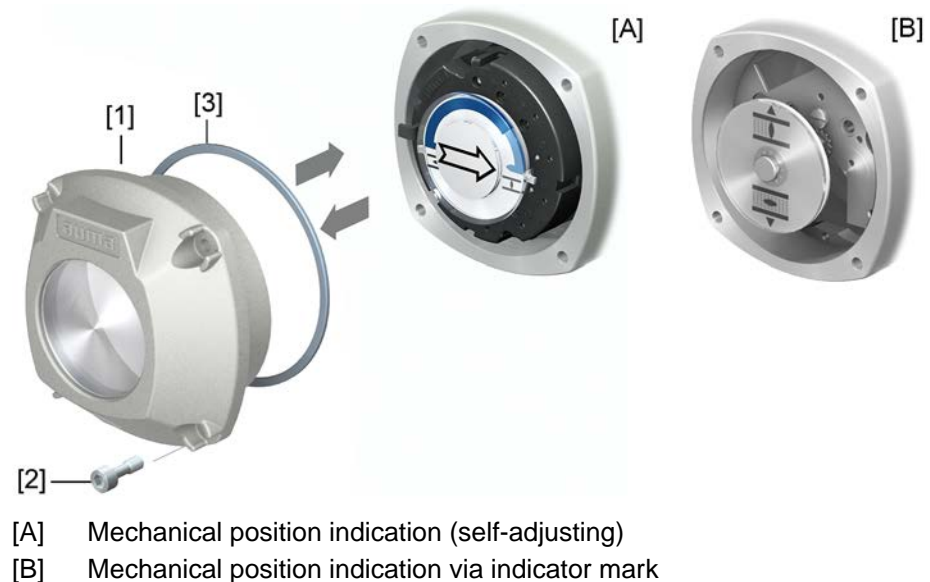



Ignition of potentially explosive atmospheres caused by sparks.

Risk of death or serious injury.

- Before opening the flameproof enclosure, ensure absence of gas and voltage.
- Wait for 30 seconds after power cut-off prior to opening the housing.
- Handle cover and housing parts with care.
- Joint surfaces must not be damaged or soiled in any way.
- Do not jam cover during fitting.

- | | |
|--------------|---|
| Open | 1. Loosen screws [2] and remove cover [1] from the switch compartment. |
| Close | 2. Clean sealing faces of housing and cover. |
| | 3. Preserve joint surfaces with an acid-free corrosion protection agent. |
| | 4. Check whether O-ring [3] is in good condition, replace if damaged. |
| | 5. Apply a thin film of non-acidic grease (e.g. petroleum jelly) to the O-ring and insert it correctly. |
| | 6. Place cover [1] on switch compartment. |
| | 7. Fasten screws [2] evenly crosswise. |

11.2. Mechanical position indicator (self-adjusting)

Figure 88: Mechanical position indicator (self-adjusting)



The self-adjusting mechanical position indicator shows the valve position by means of an arrow \Rightarrow . When correctly set, the arrow points to symbol \equiv (OPEN) or \perp (CLOSED) in the end positions.

- Information** The position indications is housed in the actuator switch compartment. Opening the switch compartment for manual setting is only necessary if the gear stage setting must be modified or if the factory settings of predefined end position CLOSED (or OPEN) must be adapted when commissioning.

11.2.1. Mechanical position indicator: set

1. Move valve to end position CLOSED.



2. Push both lower discs with the symbols  (OPEN) and  (CLOSED) towards each other. The disc with the arrow is thereby  is driven:

Figure 89: Setting position in CLOSED





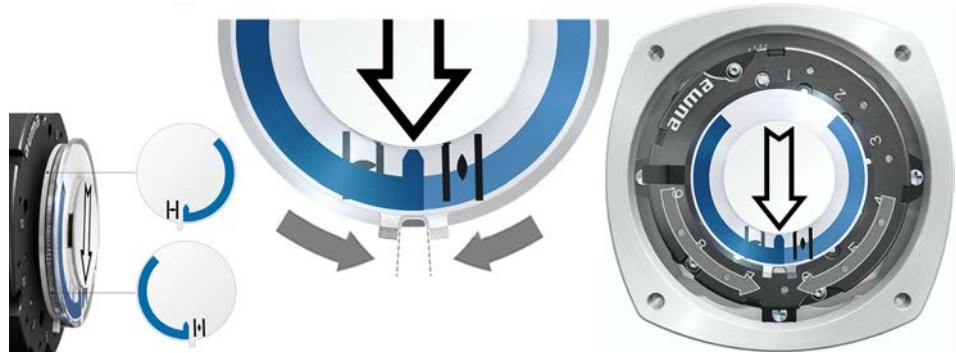

3. Move actuator to end position OPEN.
 - The arrow  rotates in direction OPEN driving the indicator disc with symbol  (OPEN) until the actuator stops in position OPEN.

Figure 90: Operation in direction OPEN (left) and position OPEN (right)



4. Check settings:
 - The setting of the mechanical position indicator is correct if the angle between the symbols  (OPEN) and  (CLOSED) ranges between approx. 120° and 280°.
 - If all three discs are turned at the same time, the indicator can be shifted in steps of 15°. Individual shifts of 5° are possible.
 - If the indicator is rotated too far (more than 280°) or if the angle is too small (below 120°), adapt the gear stage setting to the actuator turns/stroke. Refer to <Gear stage of the reduction gearing: test/set>.

11.2.2. Gear stage of the reduction gearing: test/set

The test/setting is only required if the mechanical position indicator cannot be correctly set.

1. Refer to table and check if turns/stroke correspond to the setting of the reduction gearing (stages 1– 9).

Table 27:

Turns of actuator per valve stroke and suitable reduction gearing setting		
for 1 – 500 turns/stroke [exceeding – to]	for 10 – 5,000 turns/stroke [exceeding – to]	Reduction gearing Stage
1.0 – 1.9	10 – 19	1
1.9 – 3.7	19 – 37	2
3.7 – 7.9	37 – 79	3
7.9 – 15.0	79 – 150	4
15.0 – 31.5	150 – 315	5
31.5 – 60.0	315 – 600	6
60.0 – 126	600 – 1,260	7
126 – 240	1,260 – 2,400	8
240 – 500	2,400 – 5,000	9

2. To modify settings, lift the lever at the reduction gearing and engage at the selected stage.

Figure 91: Set reduction gearing



11.3. Mechanical position indication via indicator mark (not self-adjusting)

Figure 92: Mechanical position indication via indicator mark



The mechanical position indicator shows the valve position via two indicator discs with symbols \equiv (OPEN) and \perp (CLOSED). When correctly set, the symbols OPEN/CLOSED point to the indicator mark \blacktriangle at the cover in the end positions.

Setting elements

The position indications is housed in the actuator switch compartment. The switch compartment must be opened to perform any settings. Refer to <Switch compartment: open/close>.

11.3.1. Mechanical position indicator: set

1. Move valve to end position CLOSED.

2. Turn lower indicator disc until symbol  (CLOSED) is in alignment with the ▲ mark on the cover.



3. Move actuator to end position OPEN.
4. Hold lower indicator disc in position and turn upper disc with symbol  (OPEN) until it is in alignment with the ▲ mark on the cover.



5. Move valve to end position CLOSED again.
6. Check settings:
If the symbol  (CLOSED) is no longer in alignment with ▲ mark on the cover:
 - 6.1 Repeat setting procedure.
 - 6.2 Test/set gear stage of the reduction gearing.

11.3.2. Gear stage of the reduction gearing: test/set

This test/setting is only required if the turns/stroke of the actuator were changed at a later date. The control unit may possibly have to be exchanged:

Information The adjustable stroke range is indicated on the order data sheet (e.g. “1 – 500 turns/stroke”).

1. Pull off indicator disc using a spanner as lever if required.

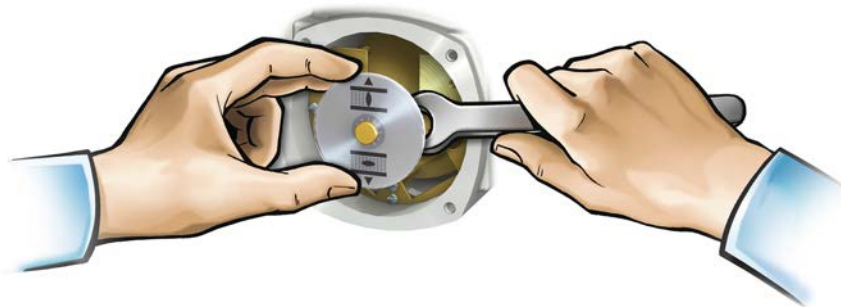

2. Refer to table and check if turns/stroke of the actuator correspond to the setting of the reduction gearing (stages 1– 9).

If the setting is **not correct**: continue with step 3.

If the setting is correct: continue with step 6.

Table 28:

MS5.2 control unit (1 to 500 turns per stroke)	
Turns/stroke above – to	Gear stage
1.0 – 1.9	1
1.9 – 3.9	2
3.9 – 7.8	3
7.8 – 15.6	4
15.6 – 31.5	5
31.5 – 62.5	6
62.5 – 125	7
125 – 250	8
250 – 500	9

Table 29:

MS50.2 control unit (10 to 5,000 turns per stroke)	
Turns/stroke above – to	Gear stage
10.0 – 19.5	1
19.5 – 39.0	2
39.0 – 78.0	3
78 – 156	4
156 – 315	5
315 – 625	6
625 – 1,250	7
1,250 – 2,500	8
2,500 – 5,000	9

3. Loosen screw [1].
4. Set crown wheel [2] to desired stage according to table.
5. Tighten screw [1].
6. Place indicator disc on shaft.
7. Set mechanical position indicator.

Figure 93: Control unit with reduction gearing

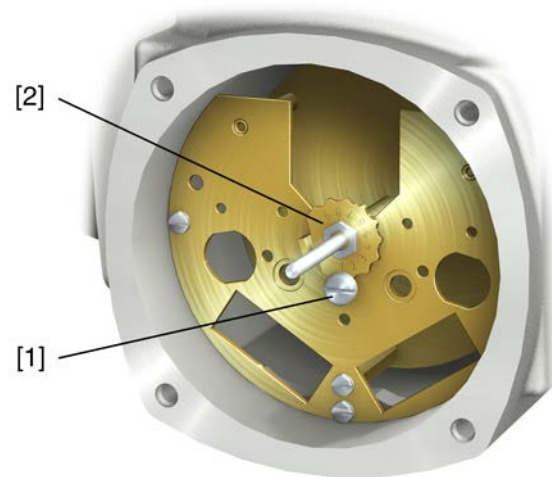

- [1] Screw
- [2] Crown wheel

12. Corrective action

12.1. Faults during commissioning

Table 30:

Faults during operation/commissioning		
Fault	Description/cause	Remedy
Mechanical position indicator cannot be set.	Reduction gearing is not suitable for turns/stroke of the actuator.	Set gear stage of the reduction gearing. The control unit might have to be exchanged.
In spite of correct setting of mechanical limit switching, actuator operates into the valve or actuator end position.	The overrun was not considered when setting the limit switching. The overrun is generated by the inertia of both the actuator and the valve and the delay time of the actuator controls.	<ul style="list-style-type: none"> Determine overrun: Overrun = travel covered from switching off until complete standstill. Set limit switching again considering the overrun. (Turn handwheel back by the amount of the overrun)
Handwheel rotates on the shaft without transmitting torque.	Actuator in version with overload protection for manual operation: Shear pin rupture due to excessive torque at handwheel.	Dismount handwheel. Replace overload protection and remount handwheel.
Actuator operation is too fast or too slow.	Speed setting is incorrect.	Change speed.
Actuator suddenly stops in end positions.	Speed reduction switched off or incorrectly set before reaching end positions.	Set speed reduction.

12.2. Fault indications and warning indications

Faults interrupt or prevent the electrical actuator operation. In the event of a fault, the display backlight is red.

Warnings have no influence on the electrical actuator operation. They only serve for information purposes. The display remains white.

Collective signals include further indications. They can be displayed via the **Details** push button. The display remains white.

Table 31:

Faults and warnings via status indications in the display		
Indication on display	Description/cause	Remedy
S0001	Instead of the valve position, a status text is displayed.	For a description of the status texts, refer to Manual (Operation and setting).
S0005 Warnings	Collective signal 02: Indicates the number of active warnings.	For indicated value > 0: Press push button Details . For details, refer to <Warnings and Out of specification> table.
S0006 Not ready REMOTE	Collective signal 04: Indicates the number of active signals.	For indicated value > 0: Press push button Details . For details, refer to <Not ready REMOTE and Function check> table.
S0007 Fault	Collective signal 03: Indicates the number of active faults. The actuator cannot be operated.	For indicated value > 0: Press push button Details to display a list of detailed indications. For details, refer to <Faults and Failure> table.
S0008 Out of specification	Collective signal 07: Indication according to NAMUR recommendation NE 107 Actuator is operated outside the normal operation conditions.	For indicated value > 0: Press push button Details . For details, refer to <Warnings and Out of specification> table.

Faults and warnings via status indications in the display		
Indication on display	Description/cause	Remedy
S0009 Function check	Collective signal 08: Indication according to NAMUR recommendation NE 107 The actuator is being worked on; output signals are temporarily invalid.	For indicated value > 0: Press push button Details. For details, refer to <Not ready REMOTE and Function check> table.
S0010 Maintenance required	Collective signal 09: Indication according to NAMUR recommendation NE 107 Recommendation to perform maintenance.	For indicated value > 0: Press push button Details to display a list of detailed indications.
S0011 Failure	Collective signal 10: Indication according to NAMUR recommendation NE 107 Actuator function failure, output signals are invalid	For indicated value > 0: Press push button Details to display a list of detailed indications. For details, refer to <Faults and Failure> table.

Table 32:

Warnings and Out of specification		
Indication on display	Description/cause	Remedy
Config. warning	Collective signal 06: Possible cause: Configuration setting is incorrect. The device can still be operated with restrictions.	Press push button Details to display a list of individual indications. For a description of the individual signals, refer to Manual (Operation and setting).
Internal warning	Collective signal 15: Device warnings The device can still be operated with restrictions.	Press push button Details to display a list of individual indications. For a description of the individual signals, refer to Manual (Operation and setting).
24 V DC external	The external 24 V DC voltage supply of the controls has exceeded the power supply limits.	Check 24 V DC voltage supply.
Wrn op.mode run time	Warning on time max. running time/h exceeded	<ul style="list-style-type: none"> Check modulating behaviour of actuator. Check parameter Perm. run time M0356, re-set if required.
Wrn op.mode starts	Warning on time max. number of motor starts (starts) exceeded	<ul style="list-style-type: none"> Check modulating behaviour of actuator. Check parameter Permissible starts M0357, re-set if required.
Failure behav. active	The failure behaviour is active since all required setpoints and actual values are incorrect.	Verify signals: <ul style="list-style-type: none"> Setpoint E1 Actual value E2 Actual process value E4 Check connection to master. Check (clear) status of master.
Wrn input AIN 1	Warning: Loss of signal analogue input 1	Check wiring.
Wrn input AIN 2	Warning: Loss of signal analogue input 2	Check wiring.
Wrn setpoint position	Warning: Loss of signal setpoint position Possible causes: For an adjusted setpoint range of e.g. 4 – 20 mA, the input signal is 0 (signal loss). For a setpoint range of 0 – 20 mA, monitoring is not possible.	Check setpoint signal.
Op. time warning	The set time (parameter Perm.op. time, manual M0570) has been exceeded. The preset operating time is exceeded for a complete travel from end position OPEN to end position CLOSED.	The warning indications are automatically cleared once a new operation command is executed. <ul style="list-style-type: none"> Check valve. Check parameter Perm.op. time, manual M0570.
Wrn controls temp.	Temperature within controls housing too high.	Measure/reduce ambient temperature.
Time not set	Real time clock has not yet been set.	Set time.
RTC voltage	Voltage of the RTC button cell is too low.	Replace button cell.
PVST fault	Partial Valve Stroke Test (PVST) could not be successfully completed.	Check actuator (PVST settings).

Warnings and Out of specification		
Indication on display	Description/cause	Remedy
PVST abort	Partial Valve Stroke Test (PVST) was aborted or could not be started.	Perform RESET or restart PVST.
Wrn no reaction	No actuator reaction to operation commands within the set reaction time.	<ul style="list-style-type: none"> Check movement at actuator. Check parameter Reaction time M0634.
Wrn FOC ¹⁾	Optical receiving signal (channel 1) incorrect (no or insufficient Rx receive level) or RS-485 format error (incorrect bit(s))	Check/repair FO cables.
Wrn FO cable budget ¹⁾	Warning: FO cable system reserve reached (critical or permissible Rx receive level)	Check/repair FO cables.
Wrn FOC connection ¹⁾	Warning FO cable connection is not available.	Fit FO cable connection.
Torque wrn OPEN	Limit value for torque warning in direction OPEN exceeded.	Check parameter Wrn torque OPEN M0768 , re-set if required.
Torque wrn CLOSE	Limit value for torque warning in direction CLOSE exceeded.	Check parameter Wrn torque CLOSE M0769 , re-set if required.
PVST required	Execution of PVST (Partial Valve Stroke Tests) is required.	
Maintenance required	Maintenance is required.	

1) For actuator controls with FOC connection

Table 33:

Faults and Failure		
Indication on display	Description/cause	Remedy
Configuration error	Collective signal 11: Configuration error has occurred.	Press push button Details to display a list of individual indications. For a description of the individual signals, refer to Manual (Operation and setting).
Config. error REMOTE	Collective signal 22: Configuration error has occurred.	Press push button Details to display a list of individual indications. For a description of the individual signals, refer to Manual (Operation and setting).
Internal error	Collective signal 14: Internal error has occurred.	AUMA service Press push button Details to display a list of individual indications. For a description of the individual signals, refer to Manual (Operation and setting).
Torque fault CLOSE	Torque fault in direction CLOSE	Perform one of the following measures: <ul style="list-style-type: none"> Issue operation command in direction OPEN. Set selector switch to position Local control (LOCAL) and reset fault indication via push button RESET. Execute reset command via fieldbus.
Torque fault OPEN	Torque fault in direction OPEN	Perform one of the following measures: <ul style="list-style-type: none"> Issue operation command in direction CLOSE. Set selector switch to position Local control (LOCAL) and reset fault indication via push button RESET. Execute reset command via fieldbus.
Phase fault	<ul style="list-style-type: none"> When connecting to a 3-ph AC system and with internal 24 V DC supply of the electronics: Phase 2 is missing. When connecting to a 3-ph AC system: One of the phases L1, L2 or L3 is missing. 	Test/connect phases.

Faults and Failure		
Indication on display	Description/cause	Remedy
Thermal fault	Motor protection tripped	<ul style="list-style-type: none"> Cool down, wait. If the fault indication display persists after cooling down: <ul style="list-style-type: none"> Set selector switch to position Local control (LOCAL) and reset fault indication via push button RESET. Execute reset command via fieldbus. Check fuses.
Fault no reaction	No actuator reaction to operation commands within the set reaction time.	Check movement at actuator.
Poti Out of Range	Potentiometer is outside the permissible range.	Check device configuration: Parameter Low limit Uspan M0832 must be less than parameter Volt.level diff. potent. M0833 .
Wrn input AIN 1	Loss of signal analogue input 1	Check wiring.
Wrn input AIN 2	Loss of signal analogue input 2	Check wiring.
Incorrect rotary direct.	Contrary to the configured direction of rotation and the active operation command, the motor turns into the wrong direction.	Check operation command control. For 3-phase AC current mains, activate phase monitoring (parameter Adapt rotary dir. M0171). Check device configuration setting (parameter Closing rotation M0176). To delete the fault indication: Disconnect actuator controls from the mains and perform reboot.
Rectifier fault	Motor protection: Fault within converter	
DMF fault OPEN ¹⁾	The torque in direction OPEN, measured at the output drive shaft using the torque measurement flange, is too high.	Check DMF trip torque OP parameter. Check DMF fault level parameter.
DMF fault CLOSE ¹⁾	The torque in direction CLOSE, measured at the output drive shaft using the torque measurement flange, is too high.	Check DMF trip torque CL parameter. Check DMF fault level parameter.

1) For actuators equipped with torque measurement flange (DMF)

Table 34:

Not ready REMOTE and Function check (collective signal 04)		
Indication on display	Description/cause	Remedy
Wrong oper. cmd	Collective signal 13: Possible causes: <ul style="list-style-type: none"> Several operation commands (e.g. OPEN and CLOSE simultaneously, or OPEN and SET-POINT operation simultaneously) A setpoint is present and the positioner is not active 	<ul style="list-style-type: none"> Check operation commands (reset/clear all operation commands and send one operation command only). Set parameter Positioner to Function active. Check setpoint. <p>Press push button  Details to display a list of individual indications.</p> <p>For a description of the individual signals, refer to Manual (Operation and setting).</p>
Sel. sw. not REMOTE	Selector switch is not in position REMOTE.	Set selector switch to position REMOTE.
Service active	Operation via service interface (Bluetooth) and AUMA CDT service software.	Exit service software.
Disabled	Actuator is in operation mode Disabled.	Check setting and status of function <Local controls enable>.
EMCY stop active	The EMERGENCY stop switch has been operated. The motor control power supply (contactors or thyristors) is disconnected.	<ul style="list-style-type: none"> Enable EMERGENCY stop switch. Reset EMERGENCY stop state by means of Reset command.
EMCY behav. active	Operation mode EMERGENCY is active (EMERGENCY signal was sent). 0 V are applied at the EMERGENCY input.	<ul style="list-style-type: none"> Detect cause for EMERGENCY signal. Verify failure source. Apply +24 V DC at EMERGENCY input.
I/O interface	The actuator is controlled via the I/O interface (parallel).	Check I/O interface.
Handwheel active	Manual operation is activated.	Start motor operation.

Not ready REMOTE and Function check (collective signal 04)		
Indication on display	Description/cause	Remedy
FailState fieldbus	Fieldbus connection available, however no process data transmission by the master.	Verify master configuration
Local STOP	A local STOP is active. Push button STOP of local controls is operated.	Release push button STOP.
Interlock	An interlock is active.	Check interlock signal.
Interlock by-pass	By-pass function is interlocked.	Check states of main and by-pass valve.
PVST active	Partial Valve Stroke Test (PVST) is active.	Wait until PVST function is complete.

Temperature monitoring of PTC tripping device

The temperature monitoring of PTC tripping device must be connected and monitored in an external system circuit. The signal is issued via an output contact.

Designation in the wiring diagram: TEMP-WARNING PTC TRIPPING DEVICE

Active signal = NC contact open (NO contact = closed)

Active signal means: The PTC tripping device temperature is not within the permitted temperature range.

Table 35:

Signal on temperature monitoring of PTC tripping device active		
	Possible causes	Remedy
for ambient temperatures below –30 °C	Heating system (wiring diagram designation: R5 H) failure	Check external power supply of heating system.
for ambient temperatures exceeding –30 °C	Heating system defective PTC tripping device defective	Switch off heater control unit M1338 Switch off external power supply of heating system. Contact AUMA service

12.2.1. Signal for temperature warning of PTC tripping device

The “Motor protection tripped” signal (wiring diagram designation: TMS–M) must be monitored:

“Motor protection tripped” = contact NC open (contact NO = closed)

When operating in combination with a suitable heating system within an ambient temperature range exceeding the indicated temperature range of the sub-assembly, the signal has to be integrated into the system circuit. The integrated heating system within actuator controls (wiring diagram designation: R5 H) must be checked in the event of the “Motor protection tripped” signal (wiring diagram designation TMS–M).

Switch off the power supply of the heating system for temperatures significantly exceeding –30 °C! Excessive device temperature signal due to failure of the heating system might be the cause.

It is imperative to ensure the presence of the power supply of the optional heating system for temperatures below –30 °C!

12.3. Fuses

12.3.1. Fuses within the actuator controls

- F5** Automatic reset fuse as short-circuit protection for external 24 V DC supply for customer (refer to wiring diagram)

12.3.2. Motor protection (thermal monitoring)

In order to protect against overheating and impermissibly high surface temperatures at the actuator, PTC thermistors are embedded in the motor winding. Motor protection trips as soon as the max. permissible winding temperature has been reached.

The actuator is switched off and the following signals are given:

- LED 3 (motor protection tripped) on the local controls is illuminated.

- The status indications **S0007** or **S0011 Failure** display a fault.
The fault **Details** is displayed when selecting **Thermal fault**.

The motor has to cool down before operation can be resumed.

Depending on the parameter setting (motor protection behaviour), the fault signal is either automatically reset or the fault signal has to be acknowledged.

The acknowledgement is made:

- in selector switch position **Local control** (LOCAL) via push button **RESET**.
- In selector switch position **Remote control** (REMOTE) with Reset command via fieldbus.

Proof-test motor protection

The functionality of the motor protection must be verified at the latest when performing the maintenance (refer to chapter <Servicing and maintenance>).

The test is performed by simulating the motor protection signal via actuator controls local controls:

Required user level: **Specialist (4)** or higher.

M ▷ **Diagnostics M0022** **TMS proof test M1950**

- Test procedure:**
1. Set selector switch to position **0** (OFF).
 2. Return to the main menu and select the simulation value in parameter **TMS proof test M1950**: Select **Thermal test**.
 3. Activate motor protection simulation: Press **Ok** push button.
The safety function is correct if no fault signal is displayed.
 4. Reset simulation: Press **Ok** push button or exit the simulation menu and reset the selector switch to its initial position.

13. Servicing and maintenance



Damage caused by inappropriate maintenance!

- Servicing and maintenance must be carried out exclusively by suitably qualified personnel having been authorised by the end user or the contractor of the plant. Therefore, we recommend contacting our service.
- Only perform servicing and maintenance tasks when the device is switched off.

AUMA Service & Support

AUMA offers extensive service such as servicing and maintenance as well as customer product training. For the contact addresses, refer to our website (www.auma.com).

13.1. Preventive measures for servicing and safe operation

The following actions are required to ensure safe device operation:

6 months after commissioning and then once a year

- Carry out visual inspection:
Cable entries, cable glands, screw plugs, blanking plugs, etc. have to be checked for correct fit and sealing. If required, tighten cable glands and blanking plugs with torque in compliance with the manufacturer's specifications.
Check actuator for damage as well as for grease or oil leakage.
- When deployed in areas where dust formation represents a potential explosion hazard, perform visual inspection for deposit of dirt or dust on a regular basis. Clean devices if required.
- Check fastening screws between actuator and gearbox/valve for tightness. If required, fasten screws while applying the tightening torques as indicated in chapter <Assembly>.
- When rarely operated: Perform test run.
- For devices with output drive type A: Press in Lithium soap EP multi-purpose grease on mineral oil base at the grease nipple with a grease gun.
Figure 94: Output drive type A

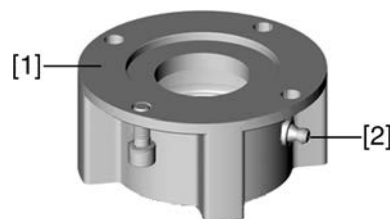

- [1] Output drive type A
- [2] Grease nipple

- Lubrication of the valve stem must be done separately.
Exception: For output drive type A in version with stem lubrication (option), the stem is lubricated together with the output drive. If the valve manufacturer interval specifications are shorter for lubricating the valve, the shorter lubrication intervals of the valve manufacturer apply.

Table 36:

Grease quantities for bearing of output drive type A				
Output drive type	A 07.2	A 10.2	A 14.2	A 16.2
Quantity [g] ¹⁾	1.5	3	5	10

1) For grease with density $\rho = 0.9 \text{ kg/dm}^3$

At the latest every 3 years

- Check functionality of motor protection. Refer to chapter <Motor protection (thermal monitoring)>.

13.2. Disconnection from the mains

If the device must be dismantled, e.g. for service purposes, it can be isolated from the mains without having to remove the wiring at the electrical connection.

13.2.1. Disconnection from the mains with KT/KM electrical connection

Figure 95: KT/KM electrical connection

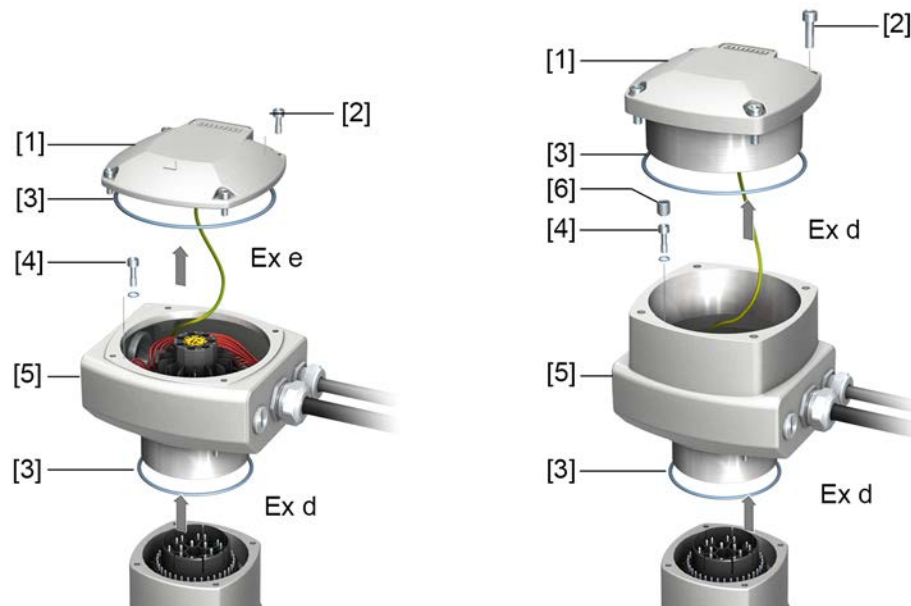

- [1] Cover
- [2] Screws for cover
- [3] O-ring
- [4] Screws (with gaskets) within connection frame
- [5] Connection frame
- [6] Grub screws within connection frame



Ignition of potentially explosive atmospheres caused by sparks.

Risk of death or serious injury.

- Before opening the flameproof enclosure, ensure absence of gas and voltage.
- Wait for 30 seconds after power cut-off prior to opening the housing.
- Handle cover and housing parts with care.
- Joint surfaces must not be damaged or soiled in any way.
- Do not jam cover during fitting.

Removing the plug:

1. Loosen the screws [2].
2. Remove cover [1].
3. For versions with terminal compartment in type of protection Ex d (flameproof enclosure): Remove grub screws [6] inside the connection frame.
4. Loosen screws [4] inside the connection frame.
5. Remove electrical connection.

Fitting the plug/socket connector:

6. Clean sealing faces of plug/socket connector, cover and housing.
7. Preserve joint surfaces with an acid-free corrosion protection agent.

8. Check whether O-rings [3] are in good condition, replace if damaged.
9. Apply a thin film of non-acidic grease (e.g. petroleum jelly) to the O-rings and insert them correctly.
10. Fit electrical connection (connection frame) and fasten screws [4] (with gaskets) evenly crosswise.
11. For versions with terminal compartment in type of protection Ex d (flameproof enclosure): Fasten grub screws [6] (tightening torque approx. 10 Nm).
Information: The flameproof enclosure is only guaranteed provided the grub screws are fastened [6].
12. Fit cover [1] and fasten screws [2] evenly crosswise.

13.2.2. Disconnection from the mains with KP/KPH and KES electrical connection



Ignition of potentially explosive atmospheres caused by sparks.

Risk of death or serious injury.

- Before opening the flameproof enclosure, ensure absence of gas and voltage.
- Wait for 30 seconds after power cut-off prior to opening the housing.
- Handle cover and housing parts with care.
- Joint surfaces must not be damaged or soiled in any way.
- Do not jam cover during fitting.

Figure 96: KP/KPH and KES electrical connection

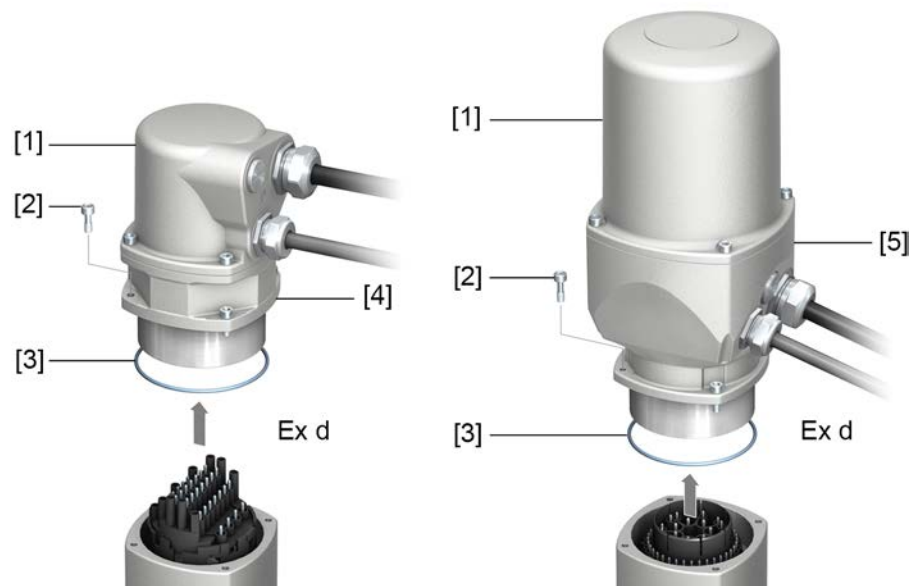

- [1] Cover
- [2] Screws for housing
- [3] O-ring
- [4] Plug-in frame (KP/KPH)
- [5] Connection frame (KES)

Removing the plug:

1. Loosen the screws [2].
2. Remove electrical connection.
- ➔ Cover [1] and plug-in type frame [4] or connection frame [5] remain together.
3. Seal open plug/socket connection, e.g. using AUMA protection cover and parking frame.

Fitting the plug/socket connector:

4. Clean sealing faces of plug/socket connector and housing.
5. Preserve joint surfaces with an acid-free corrosion protection agent.

6. Check whether O-ring [3] is in good condition, replace if damaged.
7. Apply a thin film of non-acidic grease (e.g. petroleum jelly) to the O-ring and insert it correctly.
8. Replace electrical connection and fasten screws evenly crosswise.

13.3. Maintenance

Maintenance intervals In compliance with EN 60079-17, Ex certified products either require repeated testing at an interval of 3 years or continuous monitoring by trained personnel.

Manual operation During maintenance, the mechanical parts of the handwheel activation, in particular motor coupling and retaining spring, must be checked. Replace the parts in case of visible wear.

- Lubrication**
- In the factory, the gear housing is filled with grease.
 - Additional lubrication of the gear housing is not required during operation.
 - Grease change is performed during maintenance
 - Generally after 4 to 6 years for modulating duty.
 - Generally after 6 to 8 years if operated frequently (open-close duty).
 - Generally after 10 to 12 years if operated infrequently (open-close duty).
 - We recommend replacing the seals when changing the grease.

- Notes relating to maintenance**
- Perform visual inspection of actuator and mounted accessories. Ensure that no outside damage, changes or leakage of grease and oil are visible.
 - Check actuator for unusual running or grinding noise or vibration which might be an indication of bearing or gear damage.
 - Electrical connection cables must be placed properly and in perfect condition.
 - Thoroughly touch up any possible damage to painting to prevent corrosion. Original paint in small quantities can be supplied by AUMA.
 - Cable entries, cable glands, plugs etc. have to be checked for correct tightness and sealing. Consider torques according to manufacturer's details. If required, replace the components. Only use components having an own EU type examination certificate .
 - Check whether Ex connections are fastened correctly.
 - Take care of possible discolouration of the terminals and wires. This would indicate an increased temperature.
 - For Ex housings, pay special attention to a possible collection of water. This may originate from "breathing" due to severe temperature variations (e. g. change of night and day), from damaged seals etc. Remove any water immediately.
 - The process temperature range must be within the range of the specified ambient temperature.
 - Check the flame path gaps of flameproof enclosures for dirt and corrosion.
 - Since the dimensions of all flameproof joints are strictly defined and inspected, no mechanical work (such as grinding) shall be performed on them. The joint surfaces have to be cleaned chemically (e. g. with Esso-Varsol).
 - Consult manufacturer for indications regarding flameproof joints.
 - Repair interventions on flameproof joints is not permitted.
 - Prior to fitting, preserve joint surfaces with an acid-free corrosion protection agent (e. g. Esso Rust-BAN 397).
 - Ensure that all housing covers are handled carefully and that the seals are checked.
 - All cable and motor protection components have to be checked.
 - If defects impairing the safety are detected during maintenance, repair measures have to be initiated without delay.
 - Any kind of surface coating for the joint surfaces is not permitted.
 - When replacing parts, sealing elements, etc. only original spare parts shall be used.

13.4. Disposal and recycling

Our devices have a long lifetime. However, they have to be replaced at one point in time. The devices have a modular design and may, therefore, easily be separated and sorted according to materials used, i.e.:

- Electronic scrap
- Various metals
- Plastic materials
- Greases and oils

The following generally applies:

- Greases and oils are hazardous to water and must not be released into the environment.
- Arrange for controlled waste disposal of the disassembled material or for separate recycling according to materials.
- Observe the national regulations for waste disposal.

14. Technical data

Information The following tables include standard and optional features. For detailed information on the customer-specific version, refer to the order-related data sheet. The technical data sheet can be downloaded from the Internet in both German and English at <http://www.auma.com> (please state the order number).

14.1. Technical data Multi-turn actuators

Features and functions	
Explosion protection	Refer to name plate
Certificates and standards	Certificates are attached to the device. All standards applied and their respective issues are indicated on these certificates.
Particular conditions of use	The particular conditions of use are listed on the certificates supplied.
Type of duty (Multi-turn actuators for open-close duty)	Standard: Short-time duty S2 - 15 min, classes A and B according to EN 15714-2 Option: Short-time duty S2 - 30 min, classes A and B according to EN 15714-2 For 100 % nominal voltage and +40 °C ambient temperature and at run torque load at maximum output speed.
Type of duty (Multi-turn actuators for modulating duty)	Standard: Intermittent duty S4 - 25 %, class C according to EN 15714-2 Option: Intermittent duty S4 - 50 %, class C according to EN 15714-2 For 100 % nominal voltage and +40 °C ambient temperature and at modulating torque load.
Motors	3-phase AC asynchronous motor, type IM B9 according to IEC 60034-7, IC410 cooling procedure according to IEC 60034-6
Mains voltage, mains frequency	Refer to name plate of ACV actuator controls Permissible variation of mains voltage: ±10 % Permissible variation of mains frequency: ±5 %
Overvoltage category	Category III according to IEC 60364-4-443
Insulation class	Standard: F, tropicalized Option: H, tropicalized
Motor protection	Standard: PTC thermistors (according to DIN 44082)
Self-locking	Self-locking: Speed ranges 6 – 60 rpm and 12 – 108 rpm NOT self-locking: Speed range variant 24 – 216 rpm Multi-turn actuators are self-locking if the valve position cannot be changed from standstill while torque acts upon the output drive.
Motor heater (option)	Voltages: 110 – 120 V AC, 220 – 240 V AC or 380 – 480 V AC Power depending on the size 12.5 – 25 W
Manual operation	Manual drive for setting and emergency operation, handwheel does not rotate during electrical operation. Option: Handwheel lockable Handwheel stem extension Power tool for emergency operation with square 30 mm or 50 mm
Indication for manual operation (option)	Indication whether manual operation is active/not active via single switch (1 change-over contact)
Electrical connection	Standard: AUMA Ex plug/socket connector with screw-type terminals (KP) Option: Ex plug/socket connector with terminal blocks (KES), increased safety Ex e Ex plug/socket connector with terminal blocks (KES), flameproof enclosure Ex d Ex plug/socket connector KT/KM, increased safety Ex e Ex plug/socket connector KT/KM, flameproof enclosure Ex d
Threads for cable entries	Standard: Metric threads Option: Pg-threads, NPT-threads, G-threads
Terminal plan	Terminal plan according to order number enclosed with delivery

Features and functions	
Valve attachment	Standard: B1 according to EN ISO 5210
	Option: A, B2, B3, B4, C according to EN ISO 5210 A, B, D, E according to DIN 3210 C according to DIN 3338
	Special valve attachments: AF, AK, AG, B3D, ED, DD, IB1, IB3 A prepared for permanent lubrication of stem

Electronic control unit	
Non-Intrusive setting	Magnetic limit and torque transmitter (MWG) Turns per stroke: 1 to 500 (standard) or 10 to 5,000 (option)
Position feedback signal	Via actuator controls
Torque feedback signal	Via actuator controls
Mechanical position indicator	Continuous self-adjusting indication with symbols OPEN and CLOSED
Running indication	Blinking signal via actuator controls
Heater in switch compartment	Resistance type heater with 5 W, 24 V AC

Service conditions	
Use	Indoor and outdoor use permissible
Mounting position	Any position
Installation altitude	≤ 2 000 m above sea level > 2,000 m above sea level on request
Ambient temperature	Refer to actuator name plate
Humidity	Up to 100 % relative humidity across the entire permissible temperature range
Enclosure protection according to EN 60529	IP68 with AUMA 3-phase AC motor Terminal compartment additionally sealed against interior (double sealed) According to AUMA definition, enclosure protection IP68 meets the following requirements: <ul style="list-style-type: none"> • Depth of water: maximum 8 m head of water • Duration of continuous immersion in water: Max. 96 hours • Up to 10 operations during immersion • Modulating duty is not possible during immersion. For exact version, refer to actuator controls name plate.
Pollution degree according to IEC 60664-1	Pollution degree 4 (when closed), pollution degree 2 (internal)
Corrosion protection	Standard: KS: Suitable for use in areas with high salinity, almost permanent condensation, and high pollution.
	Option: KX: Suitable for use in areas with extremely high salinity, permanent condensation, and high pollution.
	KX-G: Same as KX, however aluminium-free version (outer parts)
Coating	Double layer powder coating Two-component iron-mica combination
Colour	Standard: AUMA silver-grey (similar to RAL 7037)
	Option: Available colours on request
Lifetime	AUMA multi-turn actuators meet or exceed the lifetime requirements of EN 15714-2. Detailed information can be provided on request.
Noise level	< 72 dB (A)

14.2. Technical data Actuator controls

Features and functions																																									
Explosion protection	Refer to name plate																																								
Certificates and standards	Certificates are attached to the device. All standards applied and their respective issues are indicated on these certificates.																																								
Particular conditions of use	The particular conditions of use are listed on the certificates supplied.																																								
Power supply	<p>Standard voltages AC:</p> <table border="1"> <thead> <tr> <th colspan="5">3-phase AC</th> <th colspan="5">1-phase AC</th> </tr> <tr> <th colspan="5">Voltages/frequencies</th> <th colspan="5">Voltages/frequencies</th> </tr> <tr> <th>Volt</th> <th colspan="2">220 – 240</th> <th colspan="2">380 – 480</th> <th>Volt</th> <th colspan="2">110 – 120</th> <th colspan="2">220 – 240</th> </tr> <tr> <th>Hz</th> <th>50</th> <th>60</th> <th>50</th> <th>60</th> <th>Hz</th> <th>50</th> <th>60</th> <th>50</th> <th>60</th> </tr> </thead> </table> <p>Permissible variation of mains frequency: $\pm 5\%$ Permissible variation of mains voltage: $\pm 10\%$ –30 % for maximum 10 seconds within a range of 380 V – 480 V with the following restrictions:</p> <ul style="list-style-type: none"> • If required, the motor speed will be reduced down to nominal speed depending on the load of the actuators used • A low mains voltage increases the mains current consumption; a higher mains voltage reduces the mains current consumption • The torque limits of the actuators used might be decreased for a short time, if applicable 	3-phase AC					1-phase AC					Voltages/frequencies					Voltages/frequencies					Volt	220 – 240		380 – 480		Volt	110 – 120		220 – 240		Hz	50	60	50	60	Hz	50	60	50	60
3-phase AC					1-phase AC																																				
Voltages/frequencies					Voltages/frequencies																																				
Volt	220 – 240		380 – 480		Volt	110 – 120		220 – 240																																	
Hz	50	60	50	60	Hz	50	60	50	60																																
External supply of the electronics (option)	24 V DC: +20 % / –15 % Current consumption: Basic version approx. 250 mA, with options up to 500 mA For external electronics supply, the power supply of integral controls must have an enhanced isolation against mains voltage in compliance with IEC 61010-1 and the output power be limited to 150 VA.																																								
Rated power	The actuator controls are designed for the rated power motor power, refer to motor name plate																																								
Control and feedback signals	Via Profibus DP interface																																								
Fieldbus interface with additional input signals (option)	<ul style="list-style-type: none"> • 2 free analogue inputs (0/4 – 20 mA), 4 free digital inputs <ul style="list-style-type: none"> - Signal transmission is made via Fieldbus interface • Inputs OPEN, STOP, CLOSE, EMERGENCY, I/O interface, MODE (via opto-isolator thereof OPEN, STOP, CLOSE, MODE with one common and EMERGENCY, I/O interface respectively without common) <ul style="list-style-type: none"> - Control inputs: OPEN, STOP, CLOSE, EMERGENCY - I/O interface: Selection of control type (Fieldbus or additional input signals) - MODE: Selection between open-close duty (OPEN, STOP, CLOSE) or modulating duty (0/4 – 20 mA position setpoint) - Additionally 1 analogue input (0/4 – 20 mA) for position setpoint • Inputs OPEN, STOP, CLOSE, EMERGENCY, I/O interface, MODE (via opto-isolator thereof OPEN, STOP, CLOSE, MODE with one common and EMERGENCY, I/O interface respectively without common) <ul style="list-style-type: none"> - Control inputs: OPEN, STOP, CLOSE, EMERGENCY - I/O interface: Selection of control type (Fieldbus or additional binary OPEN, STOP, CLOSE input signals) - MODE: Selection between OPEN - CLOSE control and setpoint control (0/4 – 20 mA) - Additionally 1 analogue input (0/4 – 20 mA) for setpoint position and 1 analogue input (0/4 – 20 mA) for actual process value 																																								
Control voltage/current consumption for control inputs	<table border="1"> <tr> <td>Standard</td> <td>24 V DC, current consumption: approx. 10 mA per input</td> </tr> <tr> <td>Options:</td> <td> 48 V DC, current consumption: approx. 7 mA per input 60 V DC, current consumption: approx. 9 mA per input 100 V – 125 V DC, current consumption: approx. 15 mA per input 100 V – 120 V AC, current consumption: approx. 15 mA per input </td> </tr> </table> <p>All input signals must be supplied with the same potential.</p>	Standard	24 V DC, current consumption: approx. 10 mA per input	Options:	48 V DC, current consumption: approx. 7 mA per input 60 V DC, current consumption: approx. 9 mA per input 100 V – 125 V DC, current consumption: approx. 15 mA per input 100 V – 120 V AC, current consumption: approx. 15 mA per input																																				
Standard	24 V DC, current consumption: approx. 10 mA per input																																								
Options:	48 V DC, current consumption: approx. 7 mA per input 60 V DC, current consumption: approx. 9 mA per input 100 V – 125 V DC, current consumption: approx. 15 mA per input 100 V – 120 V AC, current consumption: approx. 15 mA per input																																								
Status signals	Via Profibus DP interface																																								

Features and functions	
Fieldbus interface with additional input signals (option)	<p>Additional, binary output signals (only available in combination with additional input signals (option))</p> <ul style="list-style-type: none"> • 6 programmable output contacts: <ul style="list-style-type: none"> - 5 potential-free NO contacts with one common, max. 250 V AC, 1 A (resistive load) Default configuration: End position CLOSED, end position OPEN, selector switch REMOTE, torque fault CLOSE, torque fault OPEN - 1 potential-free change-over contact, max. 250 V AC, 5 A (resistive load) Default configuration: Collective fault signal (torque fault, phase failure, motor protection tripped) • 6 programmable output contacts: <ul style="list-style-type: none"> - 5 potential-free change-over contacts with one common, max. 250 V AC, 1 A (resistive load) - 1 potential-free change-over contact, max. 250 V AC, 5 A (resistive load) • 6 programmable output contacts: <ul style="list-style-type: none"> - 6 potential-free change-over contacts without one common, max. 250 V AC, 5 A (resistive load) • 6 programmable output contacts: <ul style="list-style-type: none"> - 4 mains failure proof potential-free NO contacts with one common, max. 250 V AC, 1 A (resistive load), 1 potential-free NO contact, max. 250 V AC, 1 A (resistive load), 1 potential-free change-over contact, max. 250 V AC, 5 A (resistive load) • 6 programmable output contacts: <ul style="list-style-type: none"> - 4 mains failure proof potential-free NO contacts, max. 250 V AC, 5 A (resistive load), 2 potential-free change-over contacts, max. 250 V AC, 5 A (resistive load), • Analogue output signal for position feedback <ul style="list-style-type: none"> - Galvanically isolated position feedback 0/4 – 20 mA (load max. 500 Ω)
Voltage output	<p>Standard: Auxiliary voltage 24 V DC: max. 100 mA for supply of control inputs, galvanically isolated from internal voltage supply.</p> <p>Option: Auxiliary voltage 115 V AC: max. 30 mA for supply of control inputs, galvanically isolated from internal voltage supply</p>
Profibus DP-V1 (option)	Access to parameters, the electronic name plate and the operating and diagnostic data with acyclic write/read services
Profibus DP-V2 (option)	<p>Redundancy behaviour according to Profibus DP-V2 specification no. 2.212 (Primary and Backup with RedCom)</p> <p>Synchronisation of time between ACVExC 01.2 and Profibus master with subsequent time stamp of the most important events such as faults, end position and torque signals from the ACVExC 01.2</p>
Redundancy (option)	<p>Requires Profibus DP-V2 (option)</p> <p>Redundant line topology with universal redundancy behaviour according to AUMA redundancy I or II</p> <p>Redundant line topology and redundancy behaviour according to Profibus DP-V2 specification no. 2.212 (Primary and Backup with RedCom)</p>
FO cable connection (option)	<ul style="list-style-type: none"> • Connector types: ST or SC connector • FO cables <ul style="list-style-type: none"> - Multi-mode: 62,5(50)/125 µm, range approx. 2.5 km (max. 2.0 dB/km) - Single-mode: 9/125 µm, range approx. 15 km (max. 0.4 dB/km) • Topologies: Line, star and redundant loop (with single-channel Profibus interface) • Baud rate: up to 1.5 Mbit/s • Optical budget: <ul style="list-style-type: none"> - Multi-mode: 13 dB - Single-mode: 17 dB • Wave length: 1,310 nm • FO coupler by EKS required at DCS, reference addresses: AUMA or www.eks-engel.com
Local controls	<p>Standard:</p> <ul style="list-style-type: none"> • Selector switch: LOCAL - OFF - REMOTE (lockable in all three positions) • Push buttons: OPEN, STOP, CLOSE, RESET <ul style="list-style-type: none"> - Local STOP The actuator can be stopped via push button STOP of local controls if the selector switch is in position REMOTE. (Not activated when leaving the factory.) • 6 indication lights: <ul style="list-style-type: none"> - End position and running indication CLOSED (yellow), torque fault CLOSE (red), motor protection tripped (red), torque fault OPEN (red), end position and running indication OPEN (green), Bluetooth (blue) • Graphic LC display: illuminated <p>Option:</p> <ul style="list-style-type: none"> • Special colours for the indication lights: <ul style="list-style-type: none"> - End position CLOSED (green), torque fault CLOSE (blue), torque fault OPEN (yellow), motor protection tripped (violet), end position OPEN (red)

Features and functions					
ACVExC 01.2 heating system (option)	Temperature versions below –30 °C incl. heating system for connection to external power supply 230 V AC or 115 V AC or internal version 400 V AC.				
Bluetooth Communication interface	Bluetooth class II chip, version 2.1: With a range up to 10 m in industrial environments, supports the SPP Bluetooth profile (Serial Port Profile). Required accessories: <ul style="list-style-type: none"> • AUMA CDT (Commissioning and Diagnostic Tool for Windows-based PC) • AUMA Assistant App (Commissioning and Diagnostic Tool) 				
Application functions	<table border="0"> <tr> <td style="vertical-align: top;">Standard:</td> <td> <ul style="list-style-type: none"> • Selectable type of seating, limit or torque seating for end position OPEN and end position CLOSED • Torque by-pass: Adjustable duration (with adjustable peak torque during start-up time) • Start and end of stepping mode as well as ON and OFF times can be set individually for directions OPEN and CLOSE, 1 to 1,800 seconds • Operation profile with any 8 intermediate positions: Position can be set between 0 and 100 %, reaction and signal behaviour programmable • Speed profile with up to 10 ranges, speed can be individually adjusted for positions OPEN and CLOSED for each range • Running indication blinking: can be set • Speed source can be selected (REMOTE, LOCAL) • 4 internal nominal speeds can be programmed (and selected in LOCAL) • Nominal speed source can be selected for REMOTE (binary, analogue, fieldbus) • Soft start, soft stop (0.1 s – 10 s can be selected) • Positioner (positioning accuracy < 0.2 %): <ul style="list-style-type: none"> - Position setpoint via fieldbus interface - Programmable behaviour on loss of signal - Automatic adaptation of dead band (adaptive behaviour selectable) - MODE input for selecting between OPEN-CLOSE and setpoint control - Modulating duty with proportional operation (2 % – 20 %) </td> </tr> <tr> <td style="vertical-align: top;">Options:</td> <td> <ul style="list-style-type: none"> • PID process controller: with adaptive positioner, via 0/4 – 20 mA analogue inputs for process setpoint and actual process value • Automatic deblocking: Up to 5 operation trials, travel time in opposite direction can be set • Static and dynamic torque recording for both rotation directions with torque measurement flange as additional accessory </td> </tr> </table>	Standard:	<ul style="list-style-type: none"> • Selectable type of seating, limit or torque seating for end position OPEN and end position CLOSED • Torque by-pass: Adjustable duration (with adjustable peak torque during start-up time) • Start and end of stepping mode as well as ON and OFF times can be set individually for directions OPEN and CLOSE, 1 to 1,800 seconds • Operation profile with any 8 intermediate positions: Position can be set between 0 and 100 %, reaction and signal behaviour programmable • Speed profile with up to 10 ranges, speed can be individually adjusted for positions OPEN and CLOSED for each range • Running indication blinking: can be set • Speed source can be selected (REMOTE, LOCAL) • 4 internal nominal speeds can be programmed (and selected in LOCAL) • Nominal speed source can be selected for REMOTE (binary, analogue, fieldbus) • Soft start, soft stop (0.1 s – 10 s can be selected) • Positioner (positioning accuracy < 0.2 %): <ul style="list-style-type: none"> - Position setpoint via fieldbus interface - Programmable behaviour on loss of signal - Automatic adaptation of dead band (adaptive behaviour selectable) - MODE input for selecting between OPEN-CLOSE and setpoint control - Modulating duty with proportional operation (2 % – 20 %) 	Options:	<ul style="list-style-type: none"> • PID process controller: with adaptive positioner, via 0/4 – 20 mA analogue inputs for process setpoint and actual process value • Automatic deblocking: Up to 5 operation trials, travel time in opposite direction can be set • Static and dynamic torque recording for both rotation directions with torque measurement flange as additional accessory
Standard:	<ul style="list-style-type: none"> • Selectable type of seating, limit or torque seating for end position OPEN and end position CLOSED • Torque by-pass: Adjustable duration (with adjustable peak torque during start-up time) • Start and end of stepping mode as well as ON and OFF times can be set individually for directions OPEN and CLOSE, 1 to 1,800 seconds • Operation profile with any 8 intermediate positions: Position can be set between 0 and 100 %, reaction and signal behaviour programmable • Speed profile with up to 10 ranges, speed can be individually adjusted for positions OPEN and CLOSED for each range • Running indication blinking: can be set • Speed source can be selected (REMOTE, LOCAL) • 4 internal nominal speeds can be programmed (and selected in LOCAL) • Nominal speed source can be selected for REMOTE (binary, analogue, fieldbus) • Soft start, soft stop (0.1 s – 10 s can be selected) • Positioner (positioning accuracy < 0.2 %): <ul style="list-style-type: none"> - Position setpoint via fieldbus interface - Programmable behaviour on loss of signal - Automatic adaptation of dead band (adaptive behaviour selectable) - MODE input for selecting between OPEN-CLOSE and setpoint control - Modulating duty with proportional operation (2 % – 20 %) 				
Options:	<ul style="list-style-type: none"> • PID process controller: with adaptive positioner, via 0/4 – 20 mA analogue inputs for process setpoint and actual process value • Automatic deblocking: Up to 5 operation trials, travel time in opposite direction can be set • Static and dynamic torque recording for both rotation directions with torque measurement flange as additional accessory 				
Safety functions	<table border="0"> <tr> <td style="vertical-align: top;">Standard:</td> <td> <ul style="list-style-type: none"> • EMERGENCY operation (programmable behaviour) <ul style="list-style-type: none"> - Via additional input (option, low active) or via fieldbus interface - Reaction can be selected: STOP, run to end position (OPEN, CLOSED) position at defined speed - Torque monitoring can be by-passed during EMERGENCY operation </td> </tr> <tr> <td style="vertical-align: top;">Options:</td> <td> <ul style="list-style-type: none"> • Enabling local controls via Enable LOCAL digital input: Thus, actuator operation can be enabled or disabled via push buttons on local controls. • Interlock for main/by-pass valve: Enabling the operation commands OPEN or CLOSE via two digital inputs • PVST (Partial Valve Stroke Test): programmable to check the function of both actuator and actuator controls: Direction, stroke, operation time, reversing time </td> </tr> </table>	Standard:	<ul style="list-style-type: none"> • EMERGENCY operation (programmable behaviour) <ul style="list-style-type: none"> - Via additional input (option, low active) or via fieldbus interface - Reaction can be selected: STOP, run to end position (OPEN, CLOSED) position at defined speed - Torque monitoring can be by-passed during EMERGENCY operation 	Options:	<ul style="list-style-type: none"> • Enabling local controls via Enable LOCAL digital input: Thus, actuator operation can be enabled or disabled via push buttons on local controls. • Interlock for main/by-pass valve: Enabling the operation commands OPEN or CLOSE via two digital inputs • PVST (Partial Valve Stroke Test): programmable to check the function of both actuator and actuator controls: Direction, stroke, operation time, reversing time
Standard:	<ul style="list-style-type: none"> • EMERGENCY operation (programmable behaviour) <ul style="list-style-type: none"> - Via additional input (option, low active) or via fieldbus interface - Reaction can be selected: STOP, run to end position (OPEN, CLOSED) position at defined speed - Torque monitoring can be by-passed during EMERGENCY operation 				
Options:	<ul style="list-style-type: none"> • Enabling local controls via Enable LOCAL digital input: Thus, actuator operation can be enabled or disabled via push buttons on local controls. • Interlock for main/by-pass valve: Enabling the operation commands OPEN or CLOSE via two digital inputs • PVST (Partial Valve Stroke Test): programmable to check the function of both actuator and actuator controls: Direction, stroke, operation time, reversing time 				
Monitoring function	<ul style="list-style-type: none"> • Valve overload protection: adjustable, results in switching off and generates fault signal • Motor temperature monitoring (thermal monitoring): results in switching off and generates fault indication • Monitoring the heater within actuator: generates warning signal • Monitoring of permissible on-time and number of starts: adjustable, generates warning signal • Operation time monitoring: adjustable, generates warning signal • Phase failure monitoring: results in switching off and generates fault signal 				

Features and functions	
Diagnostic functions	<ul style="list-style-type: none"> Electronic device ID with order and product data Logging of operating data: A resettable counter and a lifetime counter each for: <ul style="list-style-type: none"> Motor running time, number of starts, torque switch trippings in end position CLOSED, limit switch trippings in end position CLOSED, torque switch trippings in end position OPEN, limit switch trippings in end position OPEN, torque faults CLOSE, torque faults OPEN, motor protection trippings Time-stamped event report with history for setting, operation and faults: <ul style="list-style-type: none"> Status signals according to NAMUR recommendation NE 107: "Failure", "Function check", "Out of specification", "Maintenance required" Torque characteristics (for version with MWG in actuator): <ul style="list-style-type: none"> 3 torque characteristics (torque-travel characteristic) for opening and closing directions can be saved separately. Torque characteristics stored can be shown on the display.
Motor protection evaluation	PTC tripping device (TMS module) in combination with PTC thermistors within actuator motor
Electrical connection	Standard: AUMA Ex plug/socket connector (KT); screw-type motor terminals; push-in type control terminals Options: <ul style="list-style-type: none"> AUMA Ex plug/socket connector with terminal blocks (KES) AUMA Ex plug/socket connector with screw-type terminals (KP)
Threads for cable entries	Standard: Metric threads Options: Pg-threads, NPT-threads, G-threads
Wiring diagram	Refer to name plate

For version with MWG within actuator

Setting of limit and torque switching via local controls	
Torque feedback signal	Via fieldbus interface Galvanically isolated analogue output 0/4 – 20 mA (load max. 500 Ω).

Settings/programming the Profibus DP interface

Baud rate setting	Automatic baud rate recognition
Setting the fieldbus address	The Profibus DP address is set via the actuator controls display.
Configurable process representation via GSD file	For an optimum adaptation to the process control system, the process representation input (feedback signals) can be configured as desired.

General Profibus DP interface data

Communication protocol	Profibus DP according to IEC 61158 and IEC 61784		
Network topology	Line (fieldbus) structure. When using repeaters, tree structures can also be implemented. Coupling and uncoupling of devices during operation without affecting other devices is possible.		
Transmission medium	Twisted, screened copper cable according to IEC 61158		
Profibus DP interface	EIA-485 (RS-485)		
Transmission rate/cable length	Baud rate (kbit/s)	Max. cable length (segment length) without repeater	Possible cable length with repeater (total network cable length):
	9.6 – 93.75	1,200 m	approx. 10 km
	187.5	1,000 m	approx. 10 km
	500	400 m	approx. 4 km
	1,500	200 m	approx. 2 km
Device types	DP master class 1, e.g. central controllers such as PLC, PC, ... DP master class 2, e.g. programming/configuration tools DP slave, e.g. devices with digital and/or analogue inputs/outputs such as actuators, sensors		
Number of devices	32 devices without repeater, with repeater expandable to 126		
Fieldbus access	Token-passing between masters and polling for slaves. Mono-master or multi-master systems are possible.		

General Profibus DP interface data	
Supported Profibus DP functions	Cyclic data exchange, sync mode, freeze mode, fail safe mode
Profibus DP ident no.	0x0C4F: Standard applications with Profibus DP-V0 and DP-V1
	0x0CBD: Applications with Profibus DP-V2
Commands and signals of the Profibus DP interface	
Process representation output (command signals)	OPEN, STOP, CLOSE, position setpoint, RESET, EMERGENCY operation command, enable local controls, Interlock OPEN/CLOSE OPEN, STOP, CLOSE, speed, position setpoint, RESET, EMERGENCY operation command, enable local controls, Interlock OPEN/CLOSE
Process representation input (feedback signals)	<ul style="list-style-type: none"> • End positions OPEN, CLOSED • Actual position value • Actual torque value, requires MWG in actuator • Selector switch in position LOCAL/REMOTE • Running indication (directional) • Torque switches OPEN, CLOSED • Limit switches OPEN, CLOSED • Manual operation by handwheel or via local controls • Analogue (2) and digital (4) customer inputs
Process representation input (fault signals)	<ul style="list-style-type: none"> • Motor protection tripped • Torque switch tripped in mid-travel • Failure of analogue customer inputs
Behaviour on loss of communication	The behaviour of the actuator is programmable: <ul style="list-style-type: none"> • Stop in current position • Travel to end position OPEN or CLOSED • Travel to any intermediate position • Execute last received operation command
Service conditions	
Use	Indoor and outdoor use permissible
Mounting position	Any position
Installation altitude	≤ 2 000 m above sea level > 2,000 m above sea level on request
Ambient temperature	Refer to name plate of actuator controls
Humidity	Up to 100 % relative humidity across the entire permissible temperature range
Enclosure protection in accordance with IEC 60529	IP68 Terminal compartment additionally sealed against interior (double sealed) According to AUMA definition, enclosure protection IP68 meets the following requirements: <ul style="list-style-type: none"> • Depth of water: maximum 8 m head of water • Continuous immersion in water: maximal 96 hours • Up to 10 operations during immersion • Modulating duty is not possible during immersion. For exact version, refer to actuator controls name plate.
Pollution degree according to IEC 60664-1	Pollution degree 4 (when closed), pollution degree 2 (internal)
Vibration resistance according to IEC 60068-2-6	1 g, from 10 Hz to 200 Hz Resistant to vibration during start-up or for failures of the plant. However, a fatigue strength may not be derived from this. (Not valid in combination with gearboxes)
Corrosion protection	Standard: KS: Suitable for use in areas with high salinity, almost permanent condensation, and high pollution.
	Option: KX: Suitable for use in areas with extremely high salinity, permanent condensation, and high pollution.
Coating	Double layer powder coating Two-component iron-mica combination
Colour	Standard: AUMA silver-grey (similar to RAL 7037)
	Option: Available colours on request

Accessories	
Wall bracket	For actuator controls mounted separately from the actuator, including plug/socket connector. Connecting cable on request. Recommended for high ambient temperatures, difficult access, or in case of heavy vibration during service. Cable length between actuator and actuator controls is max. 16 m. Longer cables require an external filter (filter available on request).
Programming software	AUMA CDT (Commissioning and Diagnostic Tool for Windows-based PC) AUMA Assistant App (Commissioning and Diagnostic Tool)

Further information	
Weight	Approx. 7 kg (with AUMA plug/socket connector)
Directives	ATEX Directive: (2014/34/EU) Electromagnetic Compatibility (EMC): (2014/30/EU) Low Voltage Directive: (2014/35/EU) Machinery Directive: (2006/42/EC)

14.3. Tightening torques for screws

Table 37:

Tightening torques for screws		
Threads	Tightening torque [Nm]	
	Strength class	
	A2-70/A4-70	A2-80/A4-80
M6	7.4	10
M8	18	24
M10	36	48
M12	61	82
M16	150	200
M20	294	392
M30	1,015	1,057
M36	1,769	2,121

15. Spare parts

15.1. Multi-turn actuators SAVEx 07.2 – SAVEx 16.2/SARVEx 07.2 – SARVEx 16.2 KT/KM

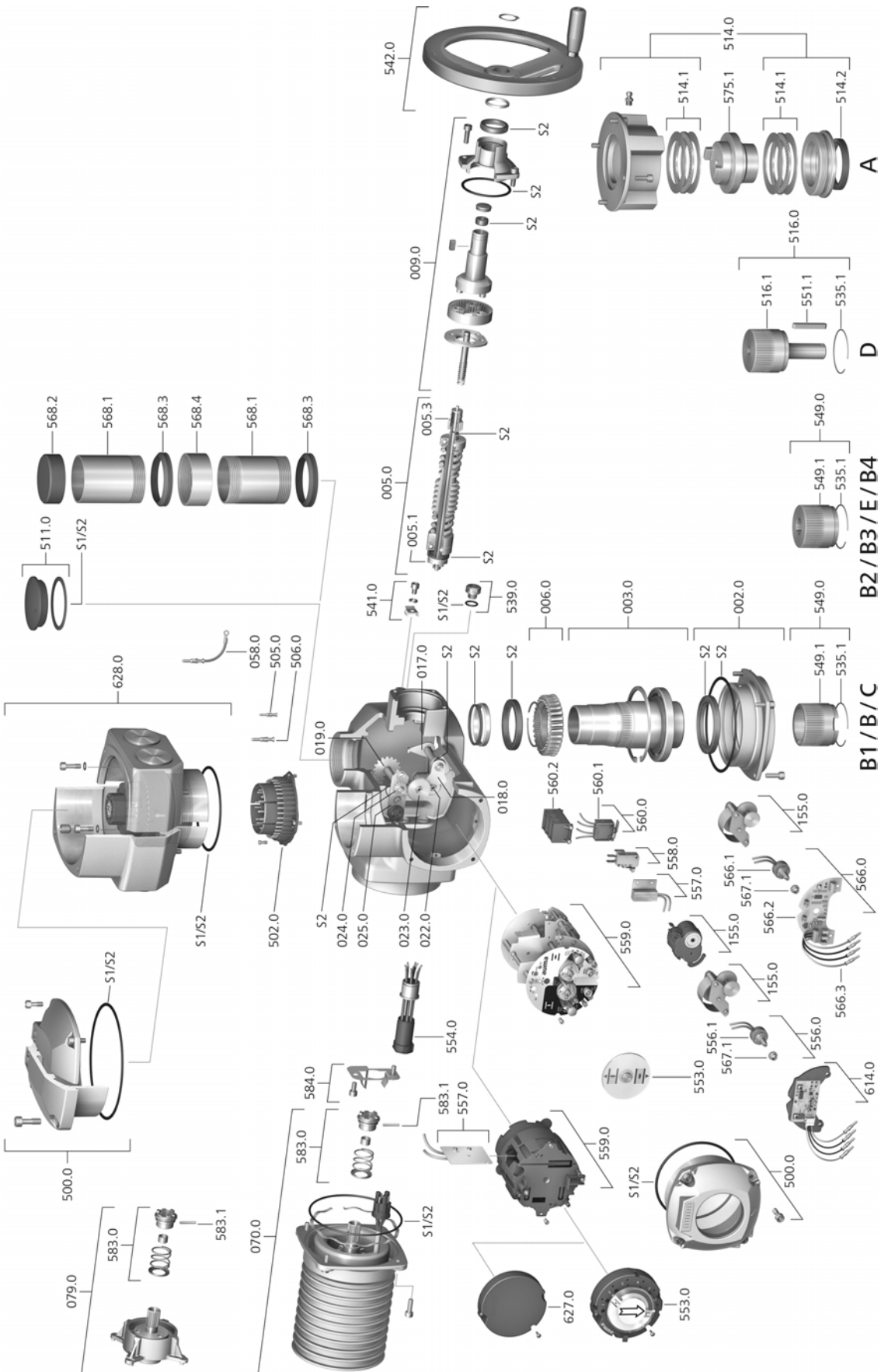

Please state device type and our order number (see name plate) when ordering spare parts. Only original AUMA spare parts should be used. Failure to use original spare parts voids the warranty and exempts AUMA from any liability. Representation of spare parts may slightly vary from actual delivery.

Ref. no.	Designation	Type	Ref. no.	Designation	Type
002.0	Bearing flange	Sub-assembly	549.1	Output drive sleeve (B/B1/B2/B3/B4/C/E)	
003.0	Hollow shaft	Sub-assembly	551.1	Parallel key	Sub-assembly
005.0	Drive shaft	Sub-assembly	553.0	Mechanical position indicator	Sub-assembly
005.1	Motor coupling		554.0	Socket carrier for motor plug/socket connector with cable harness	Sub-assembly
005.3	Manual drive coupling		556.0	Potentiometer as position transmitter	Sub-assembly
006.0	Worm wheel		556.1	Potentiometer without slip clutch	Sub-assembly
009.0	Manual gearing	Sub-assembly	557.0	Heater	Sub-assembly
017.0	Torque lever	Sub-assembly	558.0	Blinker transmitter including pins at wires (without impulse disc and insulation plate)	Sub-assembly
018.0	Gear segment		559.0–1	Electromechanical control unit with switches, including torque switching heads	Sub-assembly
019.0	Crown wheel		559.0–2	Electronic control unit with magnetic limit and torque transmitter (MWG)	Sub-assembly
022.0	Drive pinion II for torque switching	Sub-assembly	560.0–1	Switch stack for direction OPEN	Sub-assembly
023.0	Output drive wheel for limit switching	Sub-assembly	560.0–2	Switch stack for direction CLOSE	Sub-assembly
024.0	Drive wheel for limit switching	Sub-assembly	560.1	Switch for limit/torque	Sub-assembly
025.0	Locking plate	Sub-assembly	560.2–1	Switch case for direction OPEN	
058.0	Cable for protective earth	Sub-assembly	560.2–2	Switch case for direction CLOSE	
070.0	Motor (only for V... motors incl. ref. no. 079.0)	Sub-assembly	566.0	RWG position transmitter	Sub-assembly
079.0	Planetary gearing for motor drive (only for V... motors)	Sub-assembly	566.1	Potentiometer for RWG without slip clutch	Sub-assembly
155.0	Reduction gearing	Sub-assembly	566.2	Position transmitter board for RWG	Sub-assembly
500.0	Cover	Sub-assembly	566.3	Cable set for RWG	Set
502.0	Pin carrier without pins	Sub-assembly	567.1	Slip clutch for potentiometer	Sub-assembly
505.0	Pin for controls	Sub-assembly	568.1	Stem protection tube (without cap)	
506.0	Pin for motor	Sub-assembly	568.2	Protective cap for stem protection tube	
511.0	Threaded plug	Sub-assembly	568.3	V-seal	
514.0	Output drive type A (without stem nut)	Sub-assembly	568.4	Threaded sleeve	
514.1	Axial needle roller bearing	Sub-assembly	575.1	Stem nut for output drive type A	
514.2	Radial seal for output drive type A		583.0	Motor coupling on motor shaft	Sub-assembly
516.0	Output drive type D	Sub-assembly	583.1	Pin for motor coupling	
516.1	Output drive shaft D	Sub-assembly	584.0	Retaining spring for motor coupling	Sub-assembly
535.1	Snap ring		614.0	EWG position transmitter	Sub-assembly
539.0	Screw plug	Sub-assembly	627.0	MWG 05.03 cover	
541.0	Protective earthing	Sub-assembly	628.0	Ex plug/socket connector with terminal connection (KT)	
542.0	Handwheel with ball handle	Sub-assembly	S1	Seal kit, small	Set
549.0	Output drive types (B/B1/B2/B3/B4/C/E)	Sub-assembly	S2	Seal kit, large	Set

15.2. ACVExC 01.2 KT/KM actuator controls

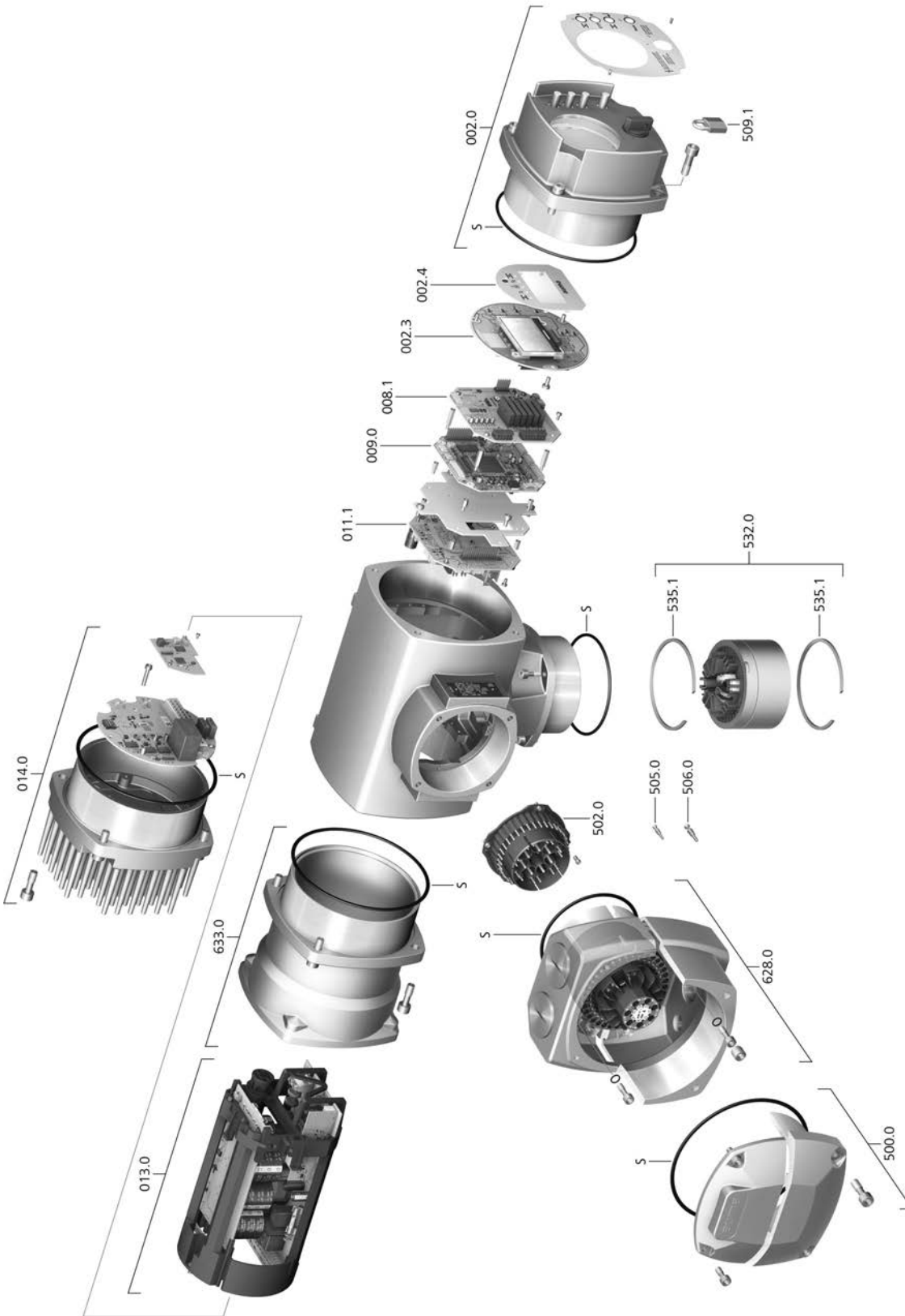

Please state device type and our order number (see name plate) when ordering spare parts. Only original AUMA spare parts should be used. Failure to use original spare parts voids the warranty and exempts AUMA from any liability. Representation of spare parts may slightly vary from actual delivery.

Ref. no.	Designation	Type
002.0	Local controls	Sub-assembly
002.3	Local controls board	Sub-assembly
002.4	Face plate for display	
008.1	I/O board	
008.1	Fieldbus board	
009.0	Logic board	Sub-assembly
011.1	ACV control board	Sub-assembly
013.0	Power supply unit/DC link	
014.0	Motor controller/switchgear	Sub-assembly
500.0	Cover	Sub-assembly
502.0	Pin carrier without pins	
505.0	Pin for controls	Sub-assembly
506.0	Pin for motor	Sub-assembly
509.1	Padlock	Sub-assembly
532.0	Cable conduit (actuator connection)	
535.1	Retaining ring	
628.0	Ex plug/socket connector (KT, KM)	
633.0	Switchgear housing	Sub-assembly
S	Seal kit	Set

15.3. ACVExC 01.2 KP/KPH actuator controls

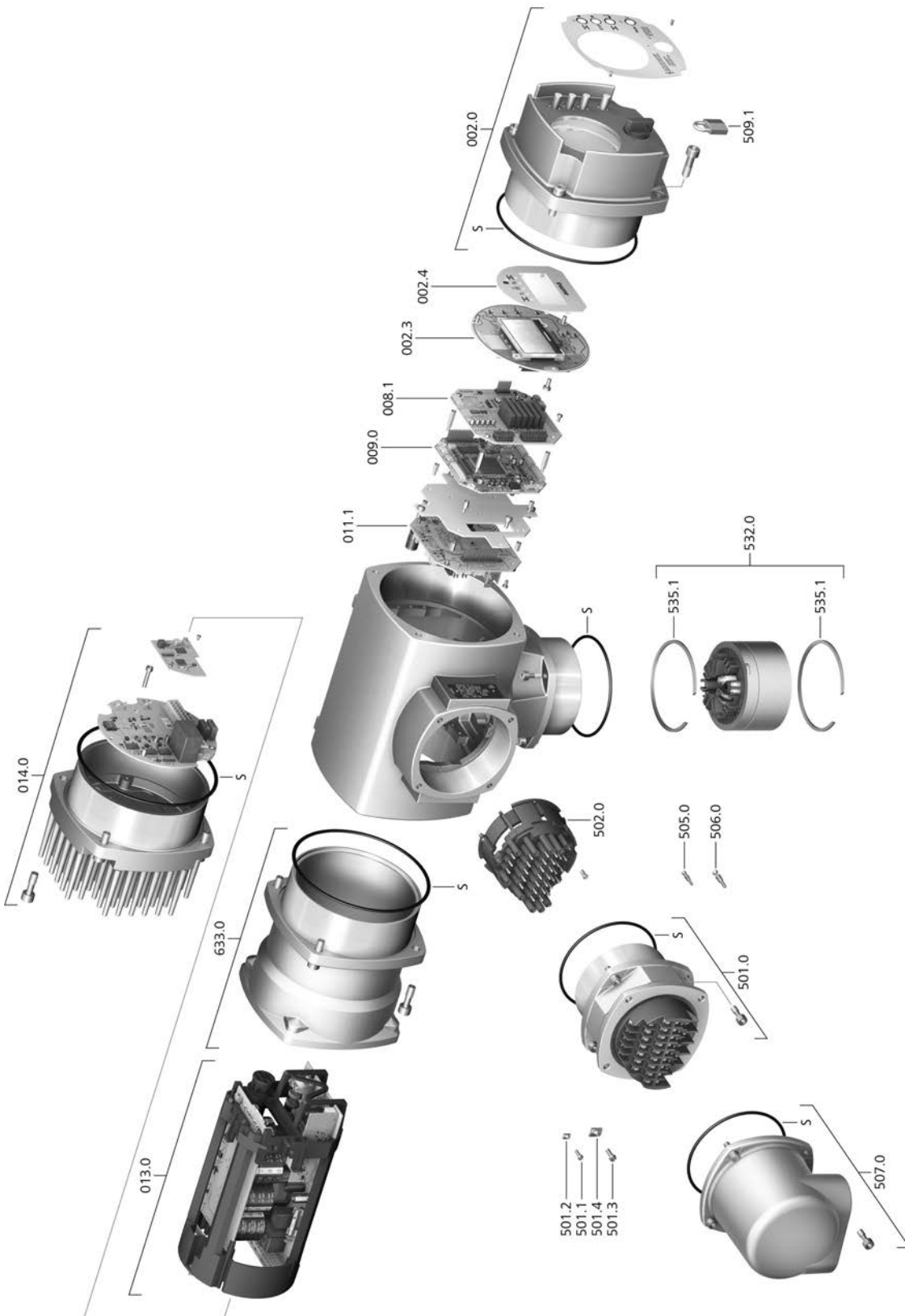

Please state device type and our order number (see name plate) when ordering spare parts. Only original AUMA spare parts should be used. Failure to use original spare parts voids the warranty and exempts AUMA from any liability. Representation of spare parts may slightly vary from actual delivery.

Ref. no.	Designation	Type
002.0	Local controls	Sub-assembly
002.3	Local controls board	Sub-assembly
002.4	Face plate for display	
008.1	I/O board	
008.1	Fieldbus board	
009.0	Logic board	Sub-assembly
011.1	ACV control board	Sub-assembly
013.0	Power supply unit/DC link	
014.0	Motor controller/switchgear	Sub-assembly
501.0	Ex plug/socket connector with screw-type terminals (KP, KPH)	Sub-assembly
501.1	Screw for control terminal	
501.2	Washer for control terminal	
501.3	Screw for power terminal	
501.4	Washer for power terminal	
502.0	Pin carrier without pins	
505.0	Pin for controls	Sub-assembly
506.0	Pin for motor	Sub-assembly
507.0	Cover for electrical connection	Sub-assembly
509.1	Padlock	Sub-assembly
532.0	Cable conduit (actuator connection)	Sub-assembly
535.1	Retaining ring	
633.0	Switchgear housing	Sub-assembly
S	Seal kit	Set

15.4. ACVExC 01.2 KES actuator controls

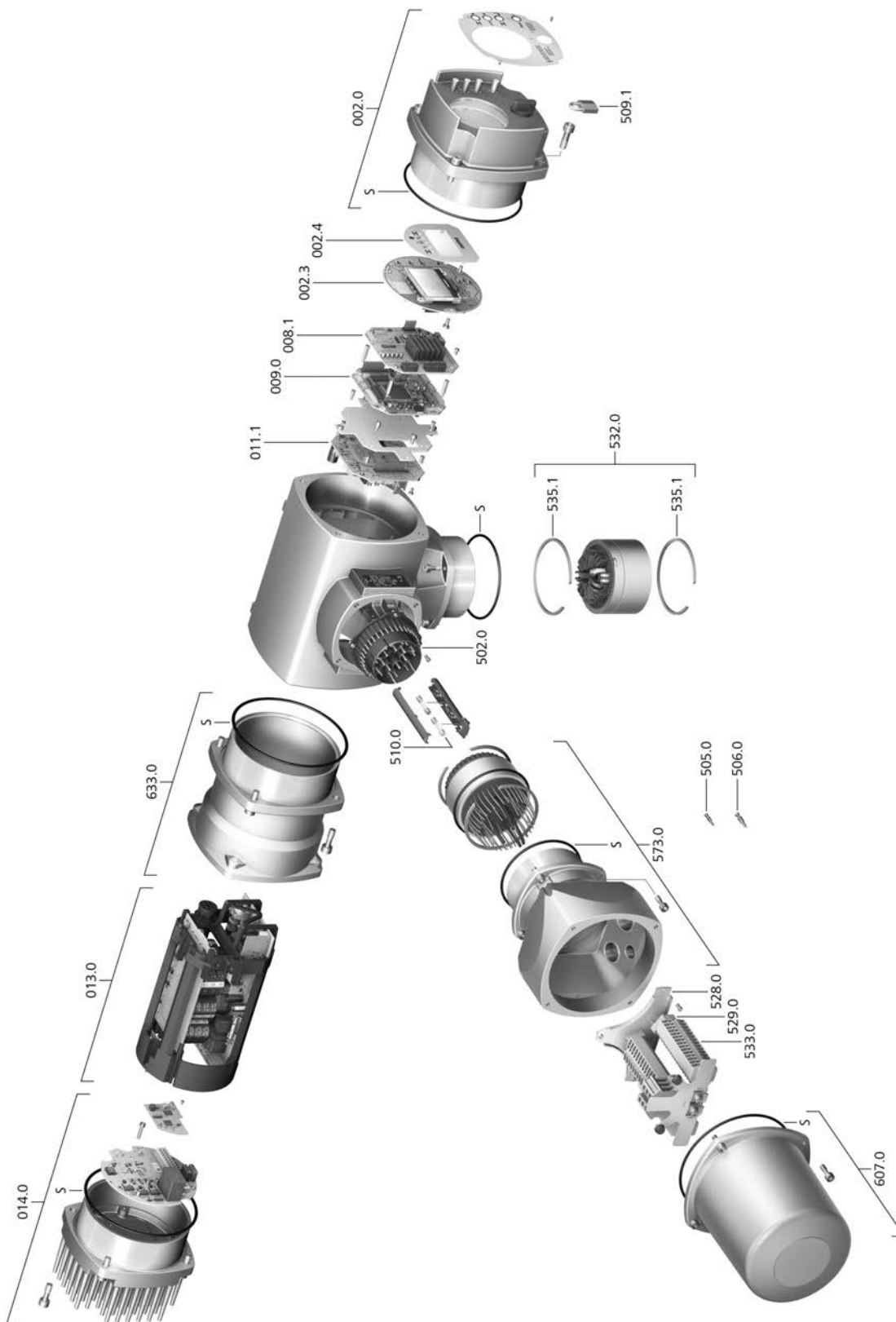

Please state device type and our order number (see name plate) when ordering spare parts. Only original AUMA spare parts should be used. Failure to use original spare parts voids the warranty and exempts AUMA from any liability. Representation of spare parts may slightly vary from actual delivery.

Ref. no.	Designation	Type
002.0	Local controls	Sub-assembly
002.3	Local controls board	Sub-assembly
002.4	Face plate for display	
008.1	I/O board	
008.1	Fieldbus board	Sub-assembly
009.0	Logic board	Sub-assembly
011.1	ACV control board	Sub-assembly
013.0	Power supply unit/DC link	
014.0	Motor controller/switchgear	Sub-assembly
502.0	Pin carrier without pins	
505.0	Pin for controls	
506.0	Pin for motor	Sub-assembly
509.1	Padlock	
510.0	Fuse kit	Sub-assembly
528.0	Terminal frame (without terminals)	Sub-assembly
529.0	End clamp	
532.0	Cable conduit (actuator connection)	Sub-assembly
533.0	Terminals for motor/controls	
535.1	Retaining ring	
573.0	Ex plug/socket connector with terminal blocks (KES)	Sub-assembly
607.0	Cover	
633.0	Switchgear housing	Sub-assembly
S	Seal kit	Set

Index

A

Accessories (electrical connection)	47
Accessories for assembly	24
Actual value - indication on display	59
Actuator controls wiring diagram	11
Actuator operation from remote	51
Actuator terminal plan	11, 13
Ambient temperature	10, 11, 97, 102
Analogue signals	66
Applications	6
Approval plate	12
Assembly	17
Assistant App	13
AUMA Assistant App	9, 13
AUMA Cloud	9

B

Blanking plug	28
Bluetooth	9

C

Cable entries	96
Cable glands	28
Cables	28
Cable set	47
CDT	9
Coating	97, 102
Colour	97, 102
Commissioning	5
Commissioning (indications on display)	57
Commission number	10
Connecting cable	47
Connecting cables	28
Control	11, 13
Control inputs Potential	27
Control voltage	13
Corrective action	85
Corrosion protection	15, 97, 102
Cross section (fieldbus cable)	28
Current consumption	27
Current type	26

D

Data Matrix code	13
Digital outputs	65
Direct display via ID	53
Direction of rotation	74, 76
Directives	5
Display (indications)	57
Disposal	95

E

Earth connection	46
Electrical connection	26, 96
Electrical connections	29
EMC	28
Enclosure protection	10, 11, 97, 102
Error - indication on display	58
Ex certificate	12
Explosion protection	12
Explosion protection marking	12

F

Failure - indication on display	62
Fault	85
Fault - indication on display	61
Features and functions	101
Fieldbus address	73
Fieldbus cable	28
Fieldbus cables	34, 40, 45
Flange size	12
Frequency range	26
Function check - indication on display	61
Fuse	27
Fuses	89

G

GSD file	65
----------	----

H

Handwheel	17
Heating system	27, 89, 89
Hollow shaft	76
Humidity	97, 102

I

Incorrect entry	55
Indication lights	63
Indications	57
Indications on display	57
Indicator disc	64, 79, 81
Indicator mark	64
Input current	13
Input signal	13
Input signals Potential	27
Inspection certificate	13
Installation altitude	97, 102
Insulation class	11, 96
Intermediate position indication via LEDs	63
Intrusive	8

L		O	
Language in the display	55	Operating the actuator from local controls	50
LEDs (indication lights)	63	Operation	5, 49
Lifetime	97	Operation commands - indications on display	59
Line topology	34, 40, 45	Order number	10, 11, 13
Local actuator operation	50	Out of specification - indication on display	61
Local control	50	Output contacts	65
Local controls	50	Output drive type A	18
Local setting	51	Output drive types	18
Lubrication	94	Output drive types B	22
M		Output signals	65
Main menu	52	Output signals Potential	27
Mains/voltage range/frequency range	11	Output speed setting	72
Mains frequency	96	Overload protection	49
Mains voltage	26, 96	Overvoltage category	96
Maintenance	6, 91, 94	P	
Maintenance required - indication on display	62	Parking frame	48
Manual operation	49, 96	Password	53
Marking for explosion protection	12	Password change	54
Maximum current	11	Password entry	54
Mechanical position indicator	64, 64, 79, 81	Pollution degree	97, 102
Mechanical position indicator (self-adjusting)	79	Positioner - indication on display	59
Menu navigation	51	Position indicator	64, 64, 79, 81
Motor heater	96	Position transmitter	13
Motor operation	50	Production, year	13
Motor protection	11, 89, 96	Protection on site	26, 27
Motors	96	Protective measures	6
Motor type	11	PTC tripping device	89
Mounting position	97, 102	Push-to-run operation	51
N		Q	
Name plate	10, 10	Qualification of staff	5
Noise level	97	R	
Non-Intrusive	8	Range of application	6
Not ready REMOTE - indication on display	61	Rated current	11, 27
Number of starts	11	Rated motor power of ACVExC	11
		Rated power	11, 27
		Rated voltage	11
		Recycling	95
		Reduction gearing reductions	82
		Remote actuator operation	51
		Residual current device (RCD)	27
		Running indication	64, 64

S		W	
Safety instructions	5	Wall bracket	47
Safety instructions/warnings	5	Warnings - indication on display	60
Safety measures	28	Wire diameter (fieldbus cable)	28
Safety standards	28	Wiring diagram	13, 26
Screening (fieldbus cable)	28	Y	
Screw plugs	28	Year of production	13
Self-locking	96		
Self-retaining	51		
Serial number	10, 11, 13		
Service	91		
Servicing	91		
Setpoint - indication on display	59		
Short-circuit protection	26		
Signals	65		
Signals (analogue)	66		
Slave address	73		
Spare parts	104		
Speed range	10		
Standards	5		
Status menu	52		
Status signals	65		
Status signals Potential	27		
Stem	76		
Stem nut	21		
Stem protection tube	24		
Storage	15		
Supply networks	26		
Support	91		
T			
Technical data	96		
Temperature monitoring	89		
Temperature protection	11		
Terminal plan	26, 96		
Test certificate	12		
Test run	74		
Timeout	55		
TMS (thermal motor protection)	89		
Torque - indication on display	58		
Torque range	10		
Torque switching	68		
Transport	14		
Type designation	10, 11		
Type of duty	96		
Type of lubricant	10		
Type of networks	26		
U			
User level	53		
V			
Valve attachment	18, 97		
Valve position - indication on display	58		
Valve stem	24		
Vibration resistance	102		
Voltage range	26		



auma[®]

Solutions for a world in motion

AUMA Riester GmbH & Co. KG

P.O. Box 1362

DE 79373 Muellheim

Tel +49 7631 809 - 0

Fax +49 7631 809 - 1250

info@auma.com

www.auma.com