

**Dimensions Part-turn actuators**

**With AUMA 3-phase motor and explosion-proof plug/socket connector**

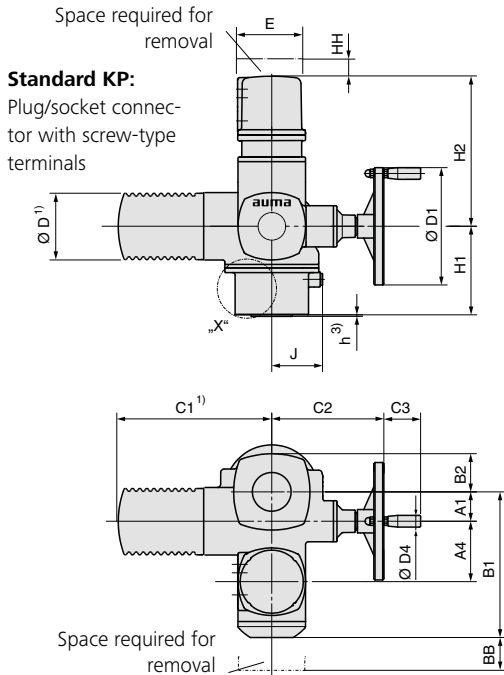

**Standard KP:**  
Plug/socket connector with screw-type terminals

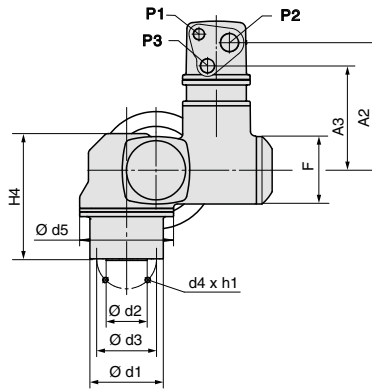

**Detail X**

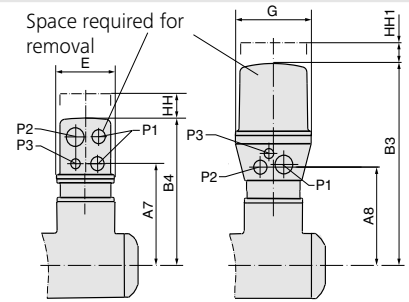
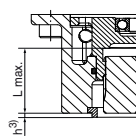

**Option KH (KPH):** Plug/socket connector with screw-type terminals  
**Option KS (KES):** Plug/socket connector with terminal blocks

- 1) Exact dimension depending on motor used
- 2) Standard, other threads on request
- 3) Allowance for spigot is not available as standard. The spigot ring is a separate component, available as option.
- 4) Combined flange F05/F07 without spigot (standard). As an alternative an individual flange F07 can be ordered with/without spigot

**Output drives according to EN ISO 5211**  
**For dimensions see overleaf**

Dimensions	SQEx 05.2		SQEx 07.2		SQEx 10.2		SQEx 12.2		SQEx 14.2			
	EN ISO 5211	F05 <sup>4)</sup>	F07 <sup>4)</sup>	F05 <sup>4)</sup>	F07 <sup>4)</sup>	F10	F10	F12	F12	F14	F14	F16
A1			40				50		50			50
A2			221				221		221			221
A3			181				181		181			181
A4			103				103		103			103
A7			207				207		207			207
A8			172				172		172			172
B1			245				255		255			255
B2			50				65		65			65
B3			395				395		395			395
B4			282				282		282			282
C1 <sup>1)</sup>			268				268		268			268
C2			186				191		191			191
C3			63				63		63			63
Ø D <sup>1)</sup>			104				104		104			104
Ø D1			160				200		200			200
Ø D4			20				20		20			20
E			115				115		115			115
F			115				115		115			115
G			150				150		150			150
H1		134		134	160	151	183	175	215	210		260
H2			257				257		257			257
H4		193		193	218	214	246	238	278	273		323
J			69				86		109			128
L max.		40		40	66	50	82	61	101	75		125
P1 <sup>2)</sup>			M20 x 1.5				M20 x 1.5		M20 x 1.5			M20 x 1.5
P2 <sup>2)</sup>			M32 x 1.5				M32 x 1.5		M32 x 1.5			M32 x 1.5
P3 <sup>2)</sup>			M25 x 1.5				M25 x 1.5		M25 x 1.5			M25 x 1.5
BB min.			180				180		180			180
HH min.			60				60		60			60
HH1 min.			130				130		130			130
Ø d1		90		90	125	125	150	150	175	175		210
Ø d2		-		-	70	70	85	85	100	100		130
Ø d3		50	70	50	70	102	102	125	140	140		165
d4		4 x M6	4 x M8	4 x M6	4 x M8	4 x M10	4 x M10	4 x M12	4 x M12	4 x M16	4 x M16	4 x M20
Ø d5				125			160		210			225
h <sup>3)</sup>		-		-	2.5	2.5	2.5	2.5	3.5	3.5		4.5
h1		12	15	12	15	16	18	19	22	25	29	32

We reserve the right to alter data according to improvements made. Previous documents become invalid with the issue of this document.

Dimensions Couplings according to EN ISO 5211

Bore according to EN ISO 5211 with keyway according to DIN 6885-1

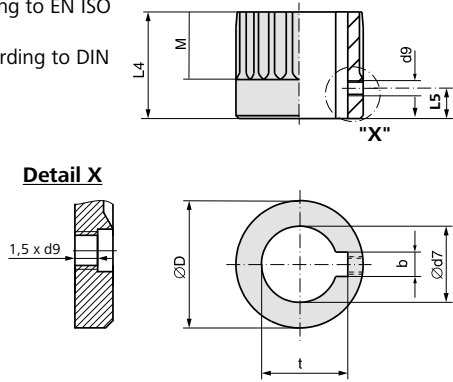

SQ../SQR..	05.2		07.2		10.2		12.2		14.2	
EN ISO 5211	F05	F07	F07	F10	F10	F12	F12	F14	F14	F16
Ø D	41.75	41.75	41.75	51.75	51.75	67.6	67.6	81.6	81.6	
b JS9 <sup>1)</sup>	6	6	6	8	8	10	10	14	14	
Ø d7 H8 <sup>2)</sup>	18	22	22	28	28	36	36	48	48	
Ø d7 max.	25.4	25.4	25.4	38	38	50	50	60	60	
d9 <sup>3)</sup>	M5	M5	M5	M6	M6	M6	M6	M6	M6	
L4	35	35	60	45	75	55	95	65	115	
L5 <sup>3)</sup>	8	8	8	10	10	10	10	10	10	
M	20	20	20	30	30	40	40	47	40	
t <sup>1)</sup>	20.8	24.8	24.8	31.3	31.3	39.3	39.3	51.8	51.8	

Square bore according to EN ISO 5211

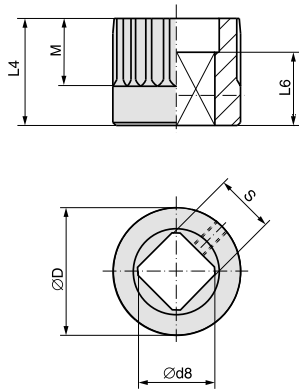

SQ../SQR..	05.2		07.2		10.2		12.2		14.2	
EN ISO 5211	F05	F07	F07	F10	F10	F12	F12	F14	F14	F16
Ø D	41.75	41.75	41.75	51.75	51.75	67.6	67.6	81.6	81.6	
Ø d8 min. <sup>2)</sup>	18.1	22.2	22.2	28.2	28.2	36.2	36.2	48.2	48.2	
Ø d8 max.	28.2	28.2	28.2	40.2 <sup>4)</sup>	40.2 <sup>4)</sup>	48.2	48.2	60.2	60.2	
L4	35	35	60	45	75	55	95	65	115	
L6 min.	30	30	30	30	30	30	30	40	40	
M	20	20	20	30	30	40	40	47	40	
s H11 <sup>2)</sup>	14	17	17	22	22	27	27	36	36	
s H11 max.	22	22	22	30 <sup>4)</sup>	30 <sup>4)</sup>	36	36	46	46	

Two-flat according to EN ISO 5211

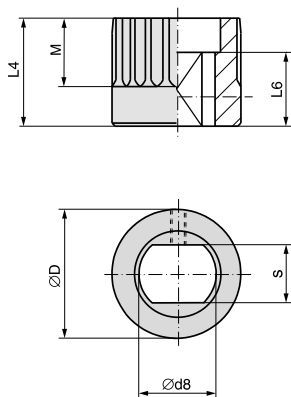

SQ../SQR..	05.2		07.2		10.2		12.2		14.2	
EN ISO 5211	F05	F07	F07	F10	F10	F12	F12	F14	F14	F16
Ø D	41.75	41.75	41.75	51.75	51.75	67.6	67.6	81.6	81.6	
Ø d8 min. <sup>2)</sup>	18.1	22.2	22.2	28.2	28.2	36.2	36.2	48.2	48.2	
Ø d8 max.	28.2	28.2	28.2	36.2	36.2	48.2 (48 <sup>5)</sup> )	48.2 (48 <sup>5)</sup> )	60.2	60.2	
L4	35	35	60	45	75	55	95	65	115	
L6 min.	25	25	25	25	25	30	30	40	40	
M	20	20	20	30	30	40	40	47	40	
s H11 <sup>2)</sup>	14	17	17	22	22	27	27	36	36	
s H11 max.	22	22	22	27	27	36 (41 <sup>5)</sup> )	36 (41 <sup>5)</sup> )	46	46	

Mounting position of the coupling within fitting dimensions according to AUMA definition

X max.	3	4	5	8
Y max.	2	5	10	10

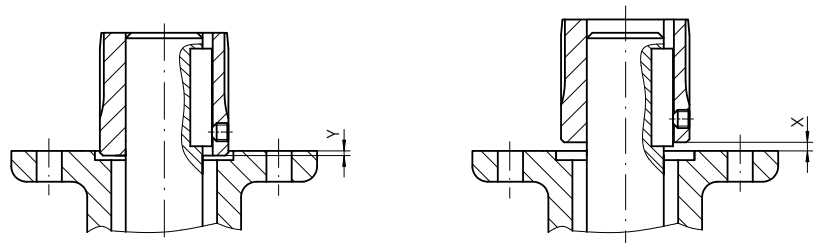

- 1) Dimensions depend on Ø d7, refer to DIN 6885-1
- 2) Recommended size according to EN ISO 5211
- 3) Thread with grub screw
- 4) According to DIN 79
- 5) According to DIN 475

We reserve the right to alter data according to improvements made. Previous documents become invalid with the issue of this document.