



Part-turn gearboxes

Worm gearboxes
for the operation of butterfly valves and ball valves
GS 630.3
Torques up to 675,000 Nm





Part-turn gearbox

The growing world population requires increasingly effective energy and water supply systems. The demands on capacity of the plants and their efficiency continue to grow, but at the same time the costs must be reduced. Pipelines with larger diameters or plants, which are operated with higher pressures, are typical of this development. Extremely high torques are required to operate butterfly and ball valves in such applications.

AUMA has met this trend with the development of the GS 630.3 part-turn gearbox. The maximum torque of this new size is almost double the torque of the GS 500: 675,000 Nm for the GS 630.3 instead of 360,000 Nm for the GS 500.

Combining the gearbox with an SA multi-turn actuator results in a part-turn actuator. However, it is also possible to use the gearbox/primary reduction gearing with high reduction ratio for manual operation of the valve.

Technical data

For detailed device selection refer to the technical datasheet Part-turn gearboxes and primary reduction gearing GS 630.3/GZ.

Torques/Lifetime

Output torques		Lifetime in operating cycles ¹ for a maximum output torque of	
100 % max. Nm	140 % max. Nm	100 %	140 %
480,000	675,000	3,000	1,000

¹ OPEN-CLOSED-OPEN operation at a swing angle of 90° and a load profile for a butterfly valve.

Combinations with multi-turn actuators

GS 630.3 with primary reduction gearing GZ 630.3	Suitable AUMA multi-turn actuator
Reduction ratio primary reduction gearing	for 100 % output torque
–	SA 48.1
4:1	SA 35.1
8:1	SA 30.1
16:1	SA 25.1
32:1	SA 16.1
64:1	SA 14.5/SA 16.1
133:1	SA 14.1/SA 14.5

Swing angle

The swing angle is adjustable between 80° and 100°. It is set in the factory to 92°, unless ordered otherwise.

Service conditions

IP 68

In the basic version, the GS 630.3 meets the requirements of enclosure protection IP 68-3 in accordance with EN 60 529. IP 68-3 means protection against submersion up to 3 m head of water.

As an option, the gearbox can also be supplied in enclosure protection IP 68-6. This version is submersible up to a maximum of 6 m head of water.

Corrosion protection

The standard AUMA corrosion protection KN is a high quality coating. This is suitable for outdoor installation and for slightly aggressive atmospheres with a low level of pollution.

For exposure to more aggressive substances, the devices are available in the protection classes KS and KX.

Painting

In the basic version, the gearboxes are supplied with primer coating.

As an option, the gearboxes can be supplied with a finish coating, usually AUMA silver-grey (similar to RAL 7037); other colours are available on request.

Ambient temperatures

The gearbox is suitable for operation at ambient temperatures of –40 °C to +80 °C.

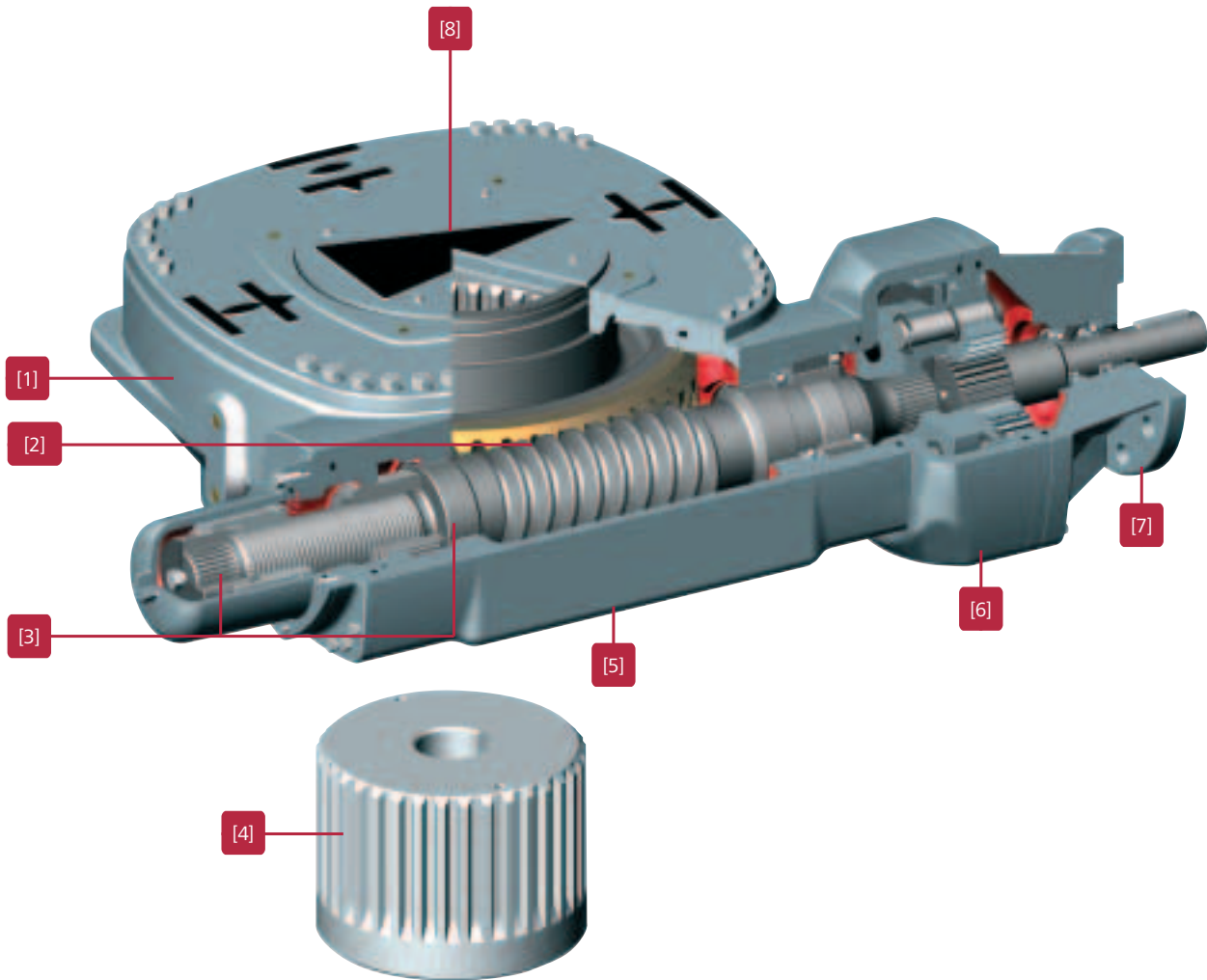

[1] Housing

The housing is made of cast iron.

[2] Gearing

Principal item is the worm gearing enabling a high reduction ratio within a single stage. The worm wheel is made of bronze to obtain good running characteristics.

[3] End stops

The internal end stops limit the swing angle. The significant advantage of the AUMA design is that only the comparatively low input torque acts on the end stops, not the high output torque. Thereby a high level of safety against damage due to overload is assured.

[4] Coupling

The separate coupling enables easier mounting of the gearbox to the valve. On request, the coupling is supplied with a suitable hole. The coupling with bore is placed on the valve shaft and secured against axial movement. The gearbox can then be mounted onto the valve flange.

[5] Valve attachment

The valve attachment is based on EN ISO 5211, however the standard does not define flanges for torques of this size. The designation of this flange size is therefore F90/AUMA.

The gearbox can be positioned on the valve at every 90°.

[6] Reduction gearing

The primary reduction gearing utilises planetary gears to reduce the required input torque. Due to the high input torques, we recommend the use of primary reduction gearing. Therefore, a smaller multi-turn actuator can be used. If the gearbox is to be operated manually, primary reduction gearing with a high reduction ratio is always required.

[7] Flange for mounting a multi-turn actuator

The flange sizes are according to EN ISO 5210 (optional DIN 3210). As an alternative, the device is equipped with a handwheel if the gearbox is to be operated manually.

[8] Pointer cover

The pointer cover follows the travel, continuously showing the valve position and can also be used as running indication.

[1] Multi-turn actuators
SA 07.2 – SA 16.2/SA 25.1 – SA 48.1
Torques from 10 to 32,000 Nm
Output speeds from 4 to 180 rpm

[2] Multi-turn actuators SA/SAR
with controls AUMATIC
Torques from 10 to 1,000 Nm
Output speeds from 4 to 180 rpm

[3] Linear actuators SA/LE
Combination of multi-turn actuator SA
with linear thrust unit LE
Thrusts from
4 kN to 217 kN
Strokes up to 500 mm
Linear speeds
from 20 to 360 mm/min

[4] Part-turn actuators
SG 05.1 – SG 12.1
Torques from 100 to 1,200 Nm
Operating times for 90° from 4 to 180 s

[5] Part-turn actuators SA/GS
Combination of multi-turn actuator SA with
part-turn gearbox GS
Torques up to 675,000 Nm

[6] Bevel gearboxes
GK 10.2 – GK 40.2
Torques up to 16,000 Nm

[7] Spur gearboxes
GST 10.1 – GST 40.1
Torques up to 16,000 Nm

[8] Worm gearboxes with base and lever
GF 50.3 – GF 250.3
Torques up to 32,000 Nm

AUMA Riester GmbH & Co. KG

P.O.Box 1362
D-79379 Muellheim
Tel +49 7631-809-0
Fax +49 7631-809-1250
riester@auma.com



[1]



[2]

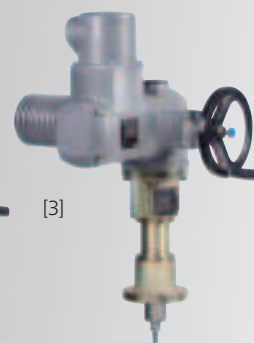

[3]



[4]



[5]



[6]



[7]



[8]

Subject to change without notice.
The product features and technical data provided do not express or imply any warranty.
Y004.590/002/en/1.10