



Lever gearboxes

GF 50.3 – GF 250.3

Worm gearboxes with base and lever

Torques up to 45,000 Nm

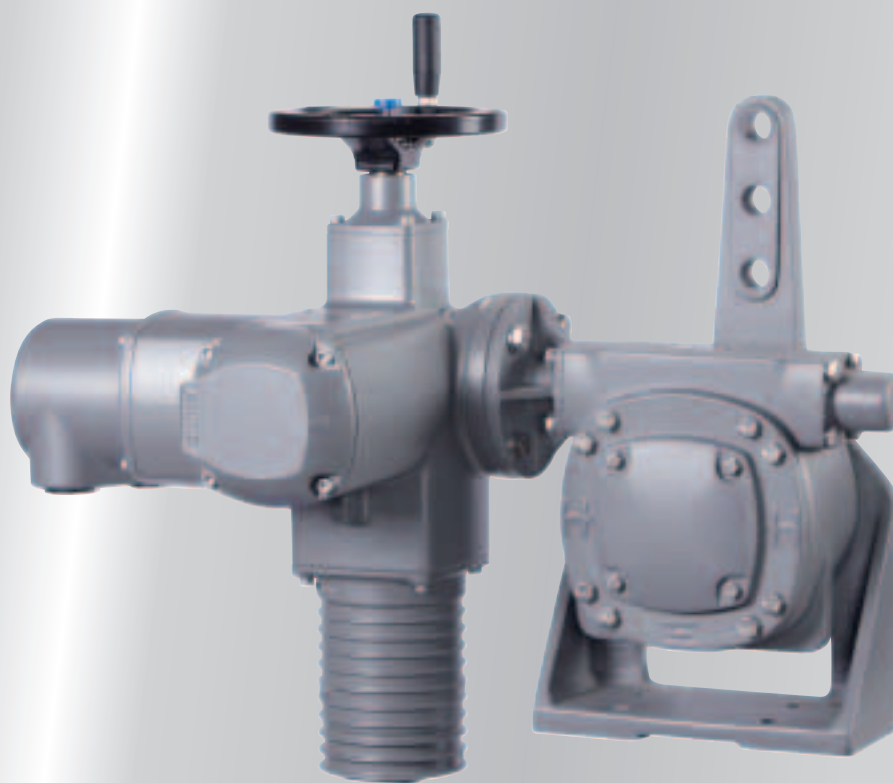



Lever gearboxes

If valves in technical process plants can only be operated via lever arrangements due to lack of space or design features, then these can be automated by using AUMA lever gearboxes. In combination with an AUMA multi-turn actuator, they form an electric lever actuator that can be operated from the control room. The gearboxes are suitable for open-close and modulating duty.

AUMA lever gearboxes are technically based on the AUMA worm gearbox type range GS.

Technical data

Technical data sheets GF 50.3 – GF 250.3 are required for detailed device selection.

Size	Lifetime	Max. output torque for input torque	
		[Nm]	approx.[Nm]
GF	Operating cycles (OPEN - CLOSE - OPEN)		
50.3	1,000	500	30
63.3	1,000	1,000	61
80.3	1,000	2,000	110
100.3	1,000	4,000	214
125.3	1,000	8,000	417
160.3	5,000	11,250	536
200.3	5,000	22,500	1,087
250.3	3,000	45,000	2,217

The torques listed are valid for gearboxes with worm wheel of spheroidal cast iron and without primary reduction gearing.

Swing angle

The swing angle is set in the factory at 92°, unless ordered otherwise. Depending on the size, swing angles between 10° and 190° are possible. Depending on the version, the swing angle can be changed at a later date on site.

Accessories

Primary reduction gearing

For reduction of the input torque, gearboxes in sizes GF 100.3 to GF 250.3 can be supplied with primary reduction gearing at the gearbox input.

Position indicator

The optional pointer cover indicates the current position of the valve at the gearbox.

Remote position indicator

If position indication is required in the control room, this can be implemented with an additional valve position indicator WSG 90.1 or WGD 90.1. This device provides the valve position as an analogue voltage (0 – 5 V) or current signal (0/4 – 20 mA).

Service conditions

Enclosure protection IP

AUMA products in the standard version conform to enclosure protection IP 67 according to EN 60 529. IP 67 means protection against immersion up to max. 1 m head of water for max. 30 minutes.

Corrosion protection

The standard AUMA corrosion protection KN is a high quality coating. This is suitable for outdoor installation and for slightly aggressive atmospheres with a low level of pollution.

For exposure to more aggressive substances, the devices are available in the protection classes KS and KX.

Explosion protection

The gearboxes correspond to explosion protection classification II2G c IIC T4 according to ATEX 94/9/EC.

Ambient temperatures¹

Version	Temperature range
Standard	-40 °C ... +80 °C
Options	-60 °C ... +60 °C
	0 °C ... +120 °C

¹ Not valid for explosion-proof version.

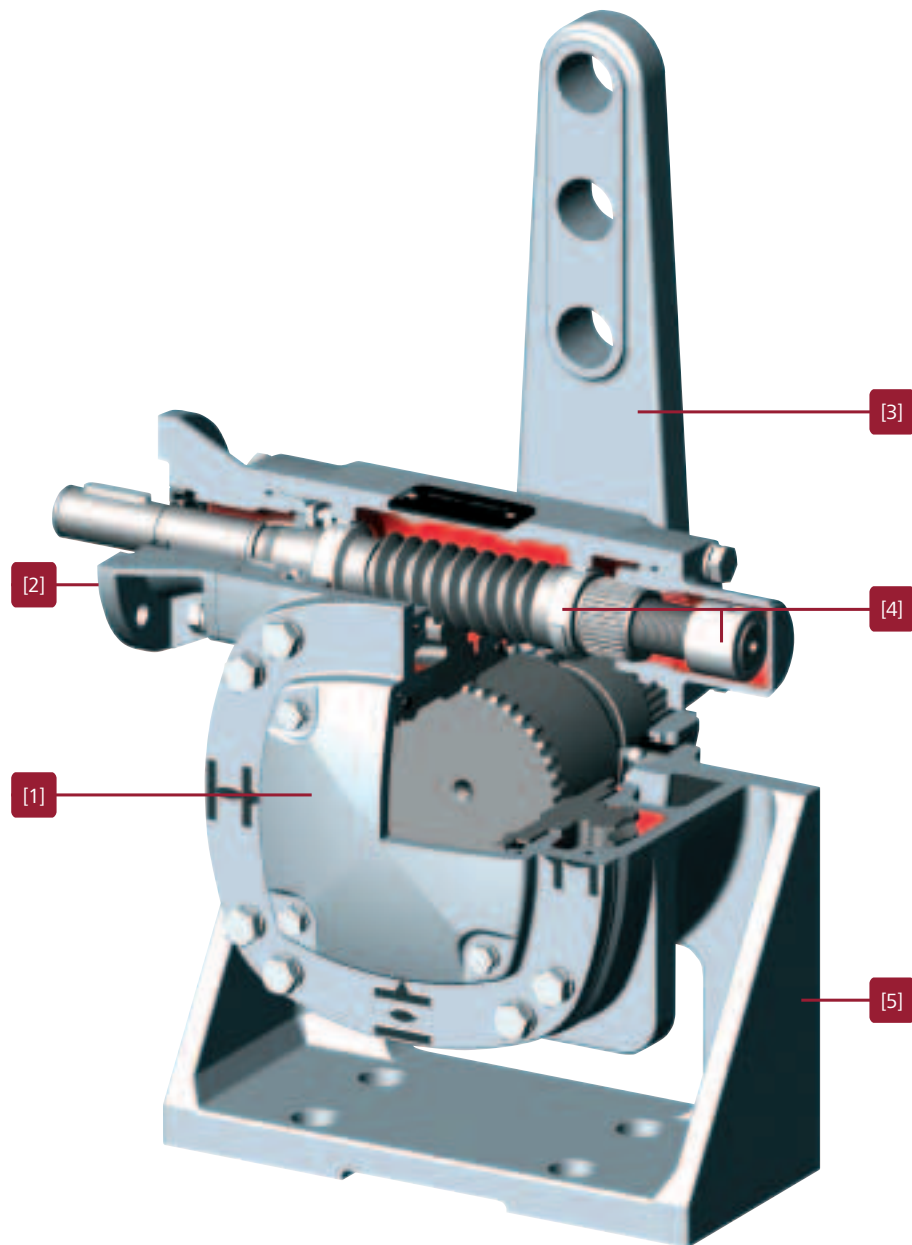

[1] Worm gearboxes GS

are the basis for the lever gearbox GF. Detailed information can be found in the brochure 'Product description Part-turn gearboxes'.

[2] Flange for mounting of multi-turn actuator

The flange sizes are according to EN ISO 5210 (optional DIN 3210). Primary reduction gearings can be fitted at the gearbox input side to increase the reduction ratio. Detailed information on AUMA multi-turn actuators can be found in the brochure 'Product description Electric multi-turn actuators'.

[3] Lever

made of spheroidal cast iron, with two or three holes for lever arrangement. The lever may be mounted to the output drive shaft in any desired position.

On request two ball joints complete with lock nuts and welding ends can be supplied.

[4] End stops

The internal end stops limit the swing angle. A significant advantage of the AUMA design is that only the comparatively low input torque acts on the end stops, not the high output torque. Thereby a high level of safety against damage due to overload is assured. Even when the end stops are damaged, the basic function of the gearbox is maintained.

[5] Base

made of spheroidal cast iron. For mounting to base, four holes for fastening bolts are available.

auma®

Solutions for a world in motion

[1] Multi-turn actuators
SA 07.2 – SA 16.2/SA 25.1 – SA 48.1
Torques from 10 to 32,000 Nm
Output speeds from 4 to 180 rpm

[2] Multi-turn actuators SA/SAR
with controls AUMATIC
Torques from 10 to 1,000 Nm
Output speeds from 4 to 180 rpm

[3] Linear actuators SA/LE
Combination of multi-turn actuator SA
with linear thrust unit LE
Thrusts from
4 kN to 217 kN
Strokes up to 500 mm
Linear speeds
from 20 to 360 mm/min

[4] Part-turn actuators
SG 05.1 – SG 12.1
Torques from 100 to 1,200 Nm
Operating times for 90° from 4 to 180 s

[5] Part-turn actuators SA/GS
Combination of multi-turn actuator SA with
part-turn gearbox GS
Torques up to 675,000 Nm

[6] Bevel gearboxes
GK 10.2 – GK 40.2
Torques up to 16,000 Nm

[7] Spur gearboxes
GST 10.1 – GST 40.1
Torques up to 16,000 Nm

[8] Worm gearboxes with base and lever
GF 50.3 – GF 250.3
Torques up to 32,000 Nm

AUMA Riester GmbH & Co. KG

P.O.Box 1362
D-79379 Muellheim
Tel +49 7631-809-0
Fax +49 7631-809-1250
riester@auma.com



[1]



[2]

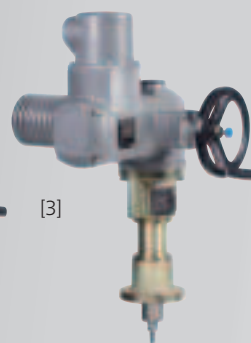

[3]



[4]



[5]



[6]



[7]



[8]



Subject to change without notice.
The product features and technical data provided do not express or imply any warranty.
Y000.303/002/en/1.10