

Dimensions worm gearboxes

GS 50.3 – GS 125.3 VZ 2.3 – VZ 4.3

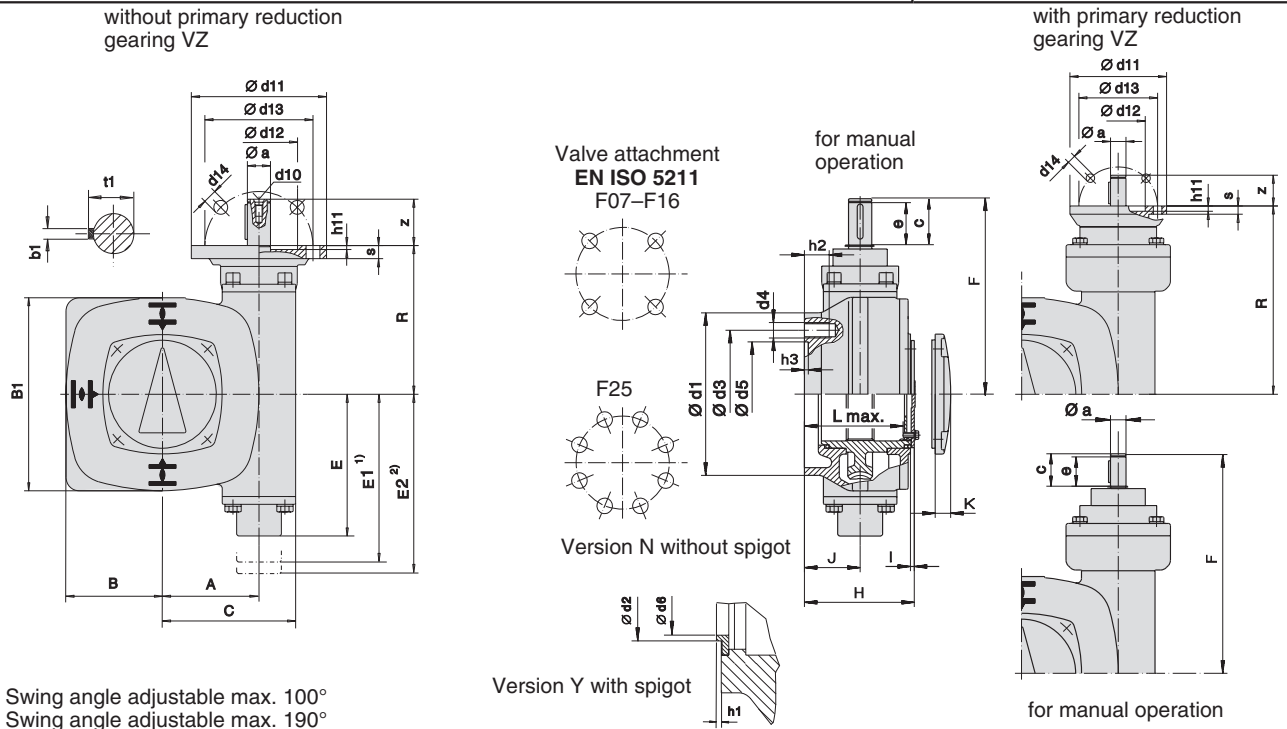

1) Swing angle adjustable max. 100°
2) Swing angle adjustable max. 190°

Dimensions	GS 50.3			GS 63.3		GS 80.3		GS 100.3				GS 125.3							
	—			—		—		—				VZ 2.3 VZ 3.3/VZ 4.3		—		VZ 2.3 VZ 3.3		VZ 4.3	
EN ISO 5211	F05	F07	F10	F10	F12	F12	F14	F14	F16	F14	F16	F16	F25	F16	F25	F16	F25		
A	50			63		80		100				100		125		125		125	
B	60	60	63	75		88		105				105		125	150	125	150	125	150
B1	108	108	125	150		175		210				210		250	300	250	300	250	300
C	77			94		111		148				148		173		173		173	
E	98			128		133		189				189		194		194		194	
E1 ¹⁾	101			135		140		213				213		218		218		218	
E2 ²⁾	114			150		155		225				225		230		230		230	
F	132			165		170		230	250	299		255		324		304		304	
H	85	80	80	91	94	97	107	142		142		145		145		145		145	
I	3			3		4		5				5		5		5		5	
J	45	40	40	42	45	47	57	75				75		75		75		75	
K	12			13		16		17				17		18		18		18	
R	100			125		130		190				259		195		264		264	
Ø a f7	16			20		20		20	30	20		30		20		30		20	
b1	5			6		6		6	8	6		8		6		8		6	
c	31.5			42		42		43	60	43		60		43		60		42	
Ø d1	65	90	125	125	150	150	175	175	210	175	210	210	300	210	300	210	300	210	300
Ø d2 f8	35	55	70	70	85	85	100	100	130	100	130	130	200	130	200	130	200	130	200
Ø d3	50	70	102	102	125	125	140	140	165	140	165	165	254	165	254	165	254	165	254
d4	M6	M8	M10	M10	M12	M12	M16	M16	M20	M16	M20	M20	M16	M20	M16	M20	M16	M20	M16
Ø d5	40	60	85	85	105	105	115	115	140	115	140	140	225	140	225	140	225	140	225
Ø d6	32.5	49	64	64	79	79	92	92	121	92	121	121	190	121	190	121	190	121	190
d10	M5			M6		M6		M10				M6		M10		M10		M6	
e	28			38		38		55				38		55		55		38	
h1	2.5			2.5	2.5	2.5	3.5	3.5	4.5	3.5	4.5	4.5	4.5	4.5	4.5	4.5	4.5	4.5	4.5
h2	10	13	16	16	19	19	25	25	32	25	32	32	25	32	25	32	25	32	25
h3	3	3.5	4	4	4	4	5	5	5	5	5	5	5	5	5	5	5	5	5
L max.	68	63	63	75	78	80	90	125	125	125	125	128	128	128	128	128	128	128	128
t1	18			22.5		22.5		22.5	33	22.5		33		22.5		33		22.5	
z	32			40		40		40	60	40		60		40		60		40	
EN ISO 5210 ³⁾	F07/F10			F07/F10		F07/F10		F10/F14		F10		F14		F10/F14		F10		F10	
DIN 3210 ³⁾	G0			G0		G0		G0/G1/2		G0		G1/2		G0/G1/2		G0		G0	

³⁾ Flange for mounting to multi-turn actuator

EN ISO 5210 (DIN 3210)	F07	F10	(G0)	F14 (G1/2)
Ø d11	90	125	125	175
Ø d12	55	70	60	100
Ø d13	70	102	102	140
Ø d14	9	11	11	18
h11	5	5	5	5
s	8	12	12	17

We reserve the right to alter data according to improvements made. Previous documents become invalid with the issue of this document.

**GS 50.3 – GS 125.3
VZ 2.3 – VZ 4.3**

**Dimensions coupling according to EN ISO 5211
DIN 6885**

Bore acc. to EN ISO 5211
with keyway acc.
to DIN 6885 P1

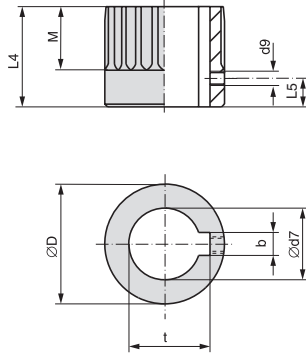

Dimensions	AUMA worm gearbox										
	GS 50.3			GS 63.3		GS 80.3		GS 100.3		GS 125.3	
EN ISO 5211	F05	F07	F10	F10	F12	F12	F14	F14	F16	F16	F25
Ø D	31.75	51.75		67.6		81.6		105.8		119.6	
b JS9 ¹⁾	6	6	8	8	10	10	14	14	18	18	20
Ø d7 ²⁾ H8	18	22	28	28	36	36	48	48	60	60	72
Ø d7 max.	20	38		50		60		80		90	
d9 ³⁾	M4	M6		M6		M6		M8		M8	
L4	35	45		55		65		80		110	
L5 ³⁾	8	10		10		10		18		18	
M	20	30		40		47		50		70	
t ¹⁾	20.8	24.8	31.3	31.3	39.3	39.3	51.8	51.8	64.4	64.4	76.9

Square bore acc. to EN ISO 5211

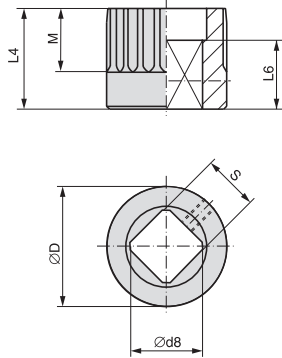

Ø D	31.75	51.75		67.6		81.6		105.8		119.6	
Ø d8 ²⁾ min.	18.1	22.2	28.2	28.2	36.2	36.2	48.2	48.2	60.2	60.2	72.2
Ø d8 max.	22.2	40.2 ⁴⁾		48.2		60.2		72.2		98.2	
L4	35	45		55		65		80		110	
L6 min.	30	30		30		40		50		50	
M	20	30		40		47		50		70	
s H11 ²⁾	14	17	22	22	27	27	36	36	46	46	55
s H11 max.	17	30 ⁴⁾		36		46		55		75	

Bore with two-flats acc. to EN ISO 5211

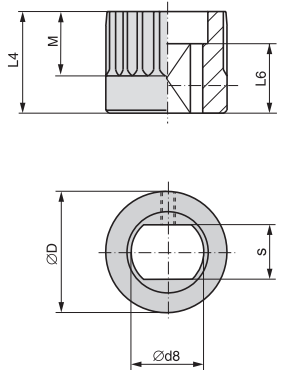

Ø D	31.75	51.75		67.6		81.6		105.8		119.6	
Ø d8 ²⁾ min.	18.1	22.2	28.2	28.2	36.2	36.2	48.2	48.2	60.2	60.2	72.2
Ø d8 max.	22.2	36.2		48.2/48 ⁵⁾		60.2		72.2		98.2	
L4	35	45		55		65		80		110	
L6 min.	25	25		30		40		45		59	
M	20	30		40		47		50		70	
s H11 ²⁾	14	17	22	22	27	27	36	36	46	46	55
s H11 max.	17	27		36/41 ⁵⁾		46		55		75	

X max.	6	14		7	10	13	23	22	22	17	17
Y max.	5	5		18	13	18	5	13	8	35	27

Mounting position of coupling

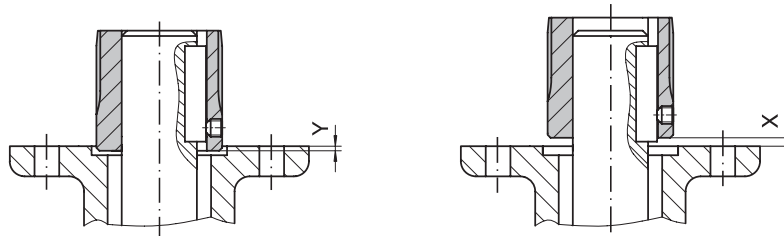

¹⁾ Dimensions depend on Ø d7, refer to DIN 6885 P1

²⁾ Recommended size according to EN ISO 5211

³⁾ Thread and grub screw

⁴⁾ according to DIN 79

⁵⁾ according to DIN 475

We reserve the right to alter data according to improvements made. Previous documents become invalid with the issue of this document.