

Dimensions Linear thrust unit

LE 12.1 – LE 200.1
SA 07.1 – SA 16.1
SAR 07.1 – SAR 16.1

with flange connections

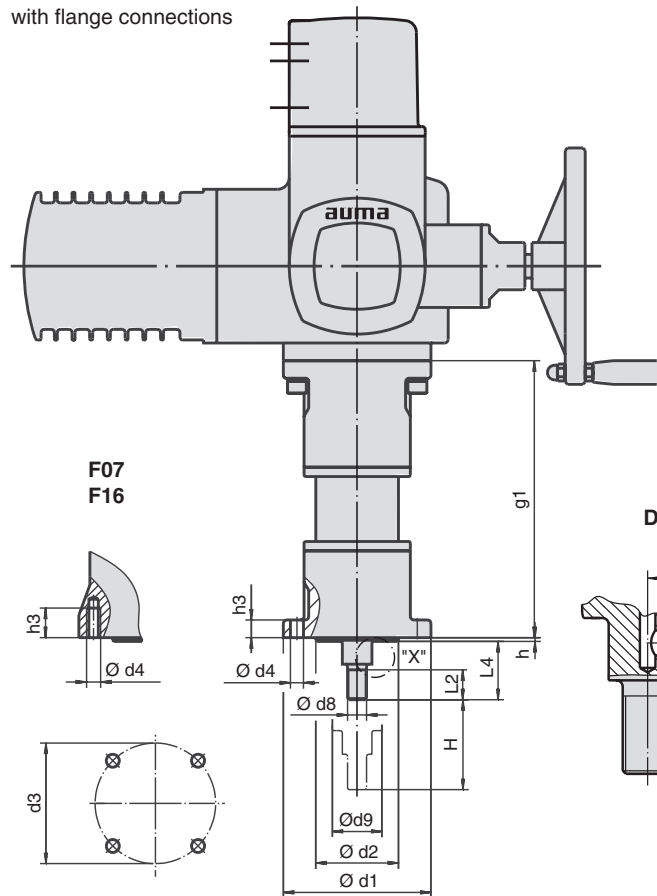

F07
F16

with base

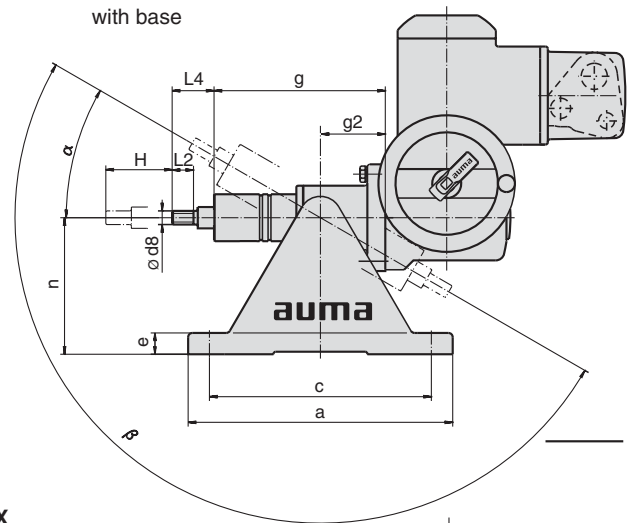

Detail X

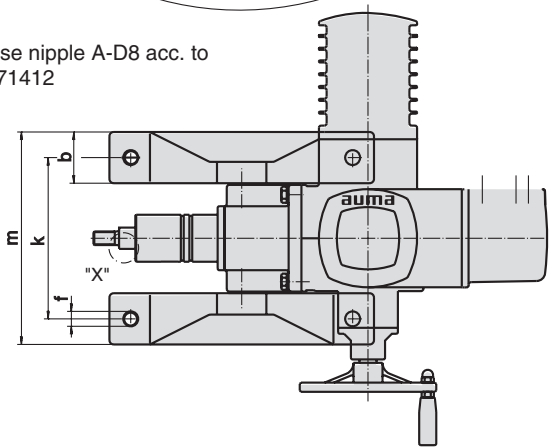
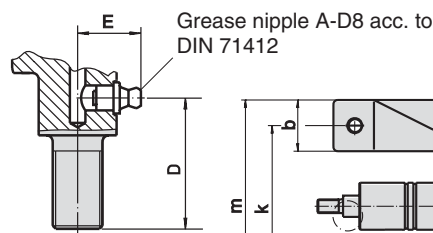

Detail refer to "Mounting dimensions linear thrust unit"
 Standard version, actuator clockwise rotation: extending stem
 Dimensions of actuator refer to sheet "Dimensions SA 07.1 – SA 16.1" latest issue

Dimensions	Linear thrust unit																											
	LE 12.1				LE 25.1				LE 50.1				LE 70.1				LE 100.1				LE 200.1							
	F07/F10				F07/F10				F10				F14				F14				F16							
suitable actuator	SA 07.1 SAR 07.1				SA 07.5 SAR 07.5				SA 10.1 SAR 10.1				SA 14.1 SAR 14.1				SA 14.5 SAR 14.5				SA 16.1 SAR 16.1							
H (Hub)	50	100	200	400	500	50	100	200	400	500	63	125	250	400	80	160	320	400	80	160	320	400	100	200	400	500		
a	310				310				310				565				565				565							
b	60				60				60				80				80				80							
c	260				260				260				500				500				500							
Ø d 1	□75/125				□75/125				125				175				175				210							
Ø d 2	55 g7/70 f8				55 g7/70 f8				70 g7				100 f8				100 f8				130 f8							
Ø d 3	70/102				70/102				102				140				140				165							
d 4	M8/11				M8/11				11				18				18				M20							
Ø d 8	M12x1.25				M16x1.5				M20x1.5				M36x3				M36x3				M42x3							
Ø d 9 -0.1	42				42				55				70				70				100							
e	25				25				25				32				32				32							
f	17.5				17.5				17.5				26				26				26							
g	195	245	345	545	645	195	245	345	545	645	238	300	425	575	296	376	536	616	296	376	536	616	367	467	667	767		
g 1	191	241	341	541	641	191	241	341	541	641	234	296	421	571	293	373	533	613	293	373	533	613	362	462	662	762		
g 2	70				70				70				70				70				80							
h	3.4/3				3.4/3				3.4				4				4				4							
h 3	20/15				20/15				15				18				18				32							
k	190				190				190				262				262				303							
m	249				249				249				342				342				383							
n	160				160				160				315				315				315							
D	37				42				43				63				63				76							
E	18				21				24				26				26				29							
L 2	20				25				30				55				55				65							
L 4 ±0,2	45				50				55				75				75				90							
α max.	30°				30°				30°				25°				25°				25°							
β max.	145°				145°				140°				140°				140°				140°							

We reserve the right to alter data according to improvements made. Previous documents become invalid with the issue of this document.

auma®

Issue **1.10**

1/1

Y000.345/002/en