

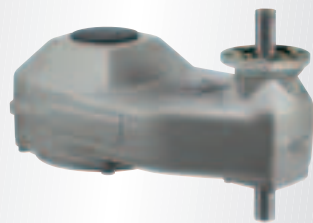

*Multi-turn gearboxes*  
Spur gearboxes  
GST 10.1 – 40.1



**Scope of these instructions:** These instructions apply to multi-turn gearboxes of the type range: GST 10.1 – GST 40.1.

<b>Table of contents</b>	<b>Page</b>
<b>1. Safety instructions . . . . .</b>	<b>3</b>
1.1 Range of application	3
1.2 Maintenance	3
1.3 Warnings and notes	3
<b>2. Technical data . . . . .</b>	<b>4</b>
<b>3. Transport, storage and packaging. . . . .</b>	<b>6</b>
3.1 Transport	6
3.2 Storage	6
3.3 Packaging	6
<b>4. Fitting the handwheel . . . . .</b>	<b>6</b>
<b>5. Mounting multi-turn actuators SA/SAR . . . . .</b>	<b>7</b>
<b>6. Mounting to valve. . . . .</b>	<b>8</b>
<b>7. Operation of valves . . . . .</b>	<b>10</b>
<b>8. Enclosure protection IP 68 . . . . .</b>	<b>11</b>
<b>9. Maintenance . . . . .</b>	<b>12</b>
9.1 General references	12
9.2 Change of grease	13
<b>10. Disposal and recycling . . . . .</b>	<b>14</b>
<b>11. Service . . . . .</b>	<b>14</b>
<b>12. Spare parts list Spur gearboxes GST 10.1 – GST 16.1 . . . . .</b>	<b>16</b>
<b>13. Spur gearboxes GST 25.1 – GST 40.1 . . . . .</b>	<b>18</b>
<b>14. Declaration of Conformity and Declaration of Incorporation. . . . .</b>	<b>20</b>
<b>Index . . . . .</b>	<b>21</b>
<b>Addresses . . . . .</b>	<b>22</b>

## 1. Safety instructions

### 1.1 Range of application

AUMA spur gearboxes GST 10.1 – GST 40.1 are used for the operation of valves (e.g. gate valves and globe valves). They are designed for manual operation as well as motor operation in conjunction with electric actuators. For other applications, please consult AUMA. The manufacturer is not liable for any possible damage resulting from use in other than the designated applications. Such risk lies entirely with the user. Observance of these operation instructions is considered as part of the designated use. Explosion-proof products are specially marked. The service conditions mentioned in these operation instructions and in the technical data sheet have to be respected during use. Other service conditions require explicit and written confirmation by the manufacturer.

### 1.2 Maintenance

The maintenance instructions (refer to page 12) must be observed, otherwise a safe operation of the spur gearbox is no longer guaranteed.

### 1.3 Warnings and notes

Failure to observe the warnings and notes may lead to serious injuries or damage. Qualified personnel must be thoroughly familiar with all warnings and notes in these operation instructions. Correct transport, proper storage, mounting and installation, as well as careful commissioning are essential to ensure a trouble-free and safe operation. The following references draw special attention to safety-relevant procedures in these operation instructions. Each is marked by the appropriate pictograph.



**This pictograph means: Note!**

“Note” marks activities or procedures which have major influence on the correct operation. Non-observance of these notes may lead to consequential damage.



**This pictograph means: Warning!**

“Warning” marks activities or procedures which, if not carried out correctly, can affect the safety of persons or material.

## 2. Technical data

Features and functions																																																																																																																																										
Type of duty	Short-time duty S2 - 15 min. (open-close duty) Intermittent duty S4 - 25 % (modulating duty) with the following maximum input speeds: GST 10.1 – GST 16.1 ≤ 45 rpm for 50 Hz GST 25.1 – GST 30.1 ≤ 11 rpm for 50 Hz																																																																																																																																									
Direction of rotation	Standard: Clockwise rotation at input shaft results in clockwise rotation at output shaft Option: GST 10.1 – GST 30.1 Reversal of rotation direction using a reversing gearbox GW 14.1																																																																																																																																									
Stages	One stage: GST 10.1 – GST 16.1 Double stage: GST 25.1 – GST 40.1																																																																																																																																									
Input shaft	GST 10.1 - GST 40.1: For standard reduction ratios, the input shaft is made of stainless steel. Exceptions: GST 16.1 5,6 : 1 GST 40.1 22 : 1 und 16 : 1 Standard: Cylindrical with parallel key according to DIN 6885.1 Option <sup>1)</sup> : Square - tapered (DIN 3233) - cylindrical																																																																																																																																									
Output torques	<table border="1"> <thead> <tr> <th rowspan="2">Type</th> <th colspan="2">Output torque</th> <th rowspan="2">Reduction ratio</th> <th colspan="2">Input torque<sup>2)</sup></th> <th rowspan="2">Factor<sup>3)</sup></th> </tr> <tr> <th>Nominal torque max. Nm</th> <th>Modulating torque max. Nm</th> <th>Nominal torque Nm</th> <th>Modulating torque Nm</th> </tr> </thead> <tbody> <tr> <td rowspan="3">GST 10.1</td> <td rowspan="3">120</td> <td rowspan="3">60</td> <td>1 : 1</td> <td>135</td> <td>66</td> <td>0,9</td> </tr> <tr> <td>1.4 : 1</td> <td>95</td> <td>46</td> <td>1,3</td> </tr> <tr> <td>2 : 1</td> <td>67</td> <td>33</td> <td>1,8</td> </tr> <tr> <td rowspan="3">GST 14.1</td> <td rowspan="3">250</td> <td rowspan="3">120</td> <td>1.4 : 1</td> <td>198</td> <td>92</td> <td>1,3</td> </tr> <tr> <td>2 : 1</td> <td>139</td> <td>66</td> <td>1,8</td> </tr> <tr> <td>2.8 : 1</td> <td>99</td> <td>48</td> <td>2,5</td> </tr> <tr> <td rowspan="3">GST 14.5</td> <td rowspan="3">500</td> <td rowspan="3">200</td> <td>2 : 1</td> <td>278</td> <td>111</td> <td>1,8</td> </tr> <tr> <td>2.8 : 1</td> <td>198</td> <td>80</td> <td>2,5</td> </tr> <tr> <td>4 : 1</td> <td>139</td> <td>55</td> <td>3,6</td> </tr> <tr> <td rowspan="3">GST 16.1</td> <td rowspan="3">1 000</td> <td rowspan="3">400</td> <td>2.8 : 1</td> <td>397</td> <td>160</td> <td>2,5</td> </tr> <tr> <td>4 : 1</td> <td>278</td> <td>111</td> <td>3,6</td> </tr> <tr> <td>5.6 : 1</td> <td>198</td> <td>80</td> <td>5,0</td> </tr> <tr> <td rowspan="3">GST 25.1</td> <td rowspan="3">2 000</td> <td rowspan="3">800</td> <td>4 : 1</td> <td>556</td> <td>222</td> <td>3,6</td> </tr> <tr> <td>5.6 : 1</td> <td>397</td> <td>160</td> <td>5,0</td> </tr> <tr> <td>8 : 1</td> <td>278</td> <td>111</td> <td>7,2</td> </tr> <tr> <td rowspan="3">GST 30.1</td> <td rowspan="3">4 000</td> <td rowspan="3">1 600</td> <td>5.6 : 1</td> <td>794</td> <td>320</td> <td>5,0</td> </tr> <tr> <td>8 : 1</td> <td>556</td> <td>222</td> <td>7,2</td> </tr> <tr> <td>11 : 1</td> <td>404</td> <td>162</td> <td>9,9</td> </tr> <tr> <td rowspan="3">GST 35.1</td> <td rowspan="3">8 000</td> <td rowspan="3">–</td> <td>8 : 1</td> <td>1 111</td> <td>–</td> <td>7,2</td> </tr> <tr> <td>11 : 1</td> <td>808</td> <td>–</td> <td>9,9</td> </tr> <tr> <td>16 : 1</td> <td>556</td> <td>–</td> <td>14,4</td> </tr> <tr> <td rowspan="3">GST 40.1</td> <td rowspan="3">16 000</td> <td rowspan="3">–</td> <td>11 : 1</td> <td>1 616</td> <td>–</td> <td>9,9</td> </tr> <tr> <td>16 : 1</td> <td>1 111</td> <td>–</td> <td>14,4</td> </tr> <tr> <td>22 : 1</td> <td>808</td> <td>–</td> <td>19,8</td> </tr> </tbody> </table>							Type	Output torque		Reduction ratio	Input torque <sup>2)</sup>		Factor <sup>3)</sup>	Nominal torque max. Nm	Modulating torque max. Nm	Nominal torque Nm	Modulating torque Nm	GST 10.1	120	60	1 : 1	135	66	0,9	1.4 : 1	95	46	1,3	2 : 1	67	33	1,8	GST 14.1	250	120	1.4 : 1	198	92	1,3	2 : 1	139	66	1,8	2.8 : 1	99	48	2,5	GST 14.5	500	200	2 : 1	278	111	1,8	2.8 : 1	198	80	2,5	4 : 1	139	55	3,6	GST 16.1	1 000	400	2.8 : 1	397	160	2,5	4 : 1	278	111	3,6	5.6 : 1	198	80	5,0	GST 25.1	2 000	800	4 : 1	556	222	3,6	5.6 : 1	397	160	5,0	8 : 1	278	111	7,2	GST 30.1	4 000	1 600	5.6 : 1	794	320	5,0	8 : 1	556	222	7,2	11 : 1	404	162	9,9	GST 35.1	8 000	–	8 : 1	1 111	–	7,2	11 : 1	808	–	9,9	16 : 1	556	–	14,4	GST 40.1	16 000	–	11 : 1	1 616	–	9,9	16 : 1	1 111	–	14,4	22 : 1	808	–	19,8
Type	Output torque		Reduction ratio	Input torque <sup>2)</sup>		Factor <sup>3)</sup>																																																																																																																																				
	Nominal torque max. Nm	Modulating torque max. Nm		Nominal torque Nm	Modulating torque Nm																																																																																																																																					
GST 10.1	120	60	1 : 1	135	66	0,9																																																																																																																																				
			1.4 : 1	95	46	1,3																																																																																																																																				
			2 : 1	67	33	1,8																																																																																																																																				
GST 14.1	250	120	1.4 : 1	198	92	1,3																																																																																																																																				
			2 : 1	139	66	1,8																																																																																																																																				
			2.8 : 1	99	48	2,5																																																																																																																																				
GST 14.5	500	200	2 : 1	278	111	1,8																																																																																																																																				
			2.8 : 1	198	80	2,5																																																																																																																																				
			4 : 1	139	55	3,6																																																																																																																																				
GST 16.1	1 000	400	2.8 : 1	397	160	2,5																																																																																																																																				
			4 : 1	278	111	3,6																																																																																																																																				
			5.6 : 1	198	80	5,0																																																																																																																																				
GST 25.1	2 000	800	4 : 1	556	222	3,6																																																																																																																																				
			5.6 : 1	397	160	5,0																																																																																																																																				
			8 : 1	278	111	7,2																																																																																																																																				
GST 30.1	4 000	1 600	5.6 : 1	794	320	5,0																																																																																																																																				
			8 : 1	556	222	7,2																																																																																																																																				
			11 : 1	404	162	9,9																																																																																																																																				
GST 35.1	8 000	–	8 : 1	1 111	–	7,2																																																																																																																																				
			11 : 1	808	–	9,9																																																																																																																																				
			16 : 1	556	–	14,4																																																																																																																																				
GST 40.1	16 000	–	11 : 1	1 616	–	9,9																																																																																																																																				
			16 : 1	1 111	–	14,4																																																																																																																																				
			22 : 1	808	–	19,8																																																																																																																																				
Operation																																																																																																																																										
Motor operation	With electric multi-turn actuator, directly flanges for mounting the multi-turn actuator, refer to separate technical data sheets.																																																																																																																																									
Manual operation	Standard: Via handwheel, directly																																																																																																																																									
	<table border="1"> <thead> <tr> <th>Type</th> <th>GST 10.1</th> <th>GST 14.1</th> <th>GST 14.5</th> <th>GST 16.1</th> <th>GST 25.1</th> <th>GST 30.1</th> <th>GST 35.1</th> <th>GST 40.1</th> </tr> </thead> <tbody> <tr> <td>Handwheel mm</td> <td>200</td> <td>315 (250)</td> <td>315</td> <td>400</td> <td>500</td> <td>500</td> <td>500</td> <td>500</td> </tr> </tbody> </table>								Type	GST 10.1	GST 14.1	GST 14.5	GST 16.1	GST 25.1	GST 30.1	GST 35.1	GST 40.1	Handwheel mm	200	315 (250)	315	400	500	500	500	500																																																																																																																
Type	GST 10.1	GST 14.1	GST 14.5	GST 16.1	GST 25.1	GST 30.1	GST 35.1	GST 40.1																																																																																																																																		
Handwheel mm	200	315 (250)	315	400	500	500	500	500																																																																																																																																		
	Option: Remote extension shaft (not contained within the AUMA product range)																																																																																																																																									
Valve attachment																																																																																																																																										
Output drive types	A, B1, B2, B3, B4 according to EN ISO 5210 A, B, D, E according to DIN 3210 C according to DIN 3338 Special output drives: AF, AK, AG, IB1, IB3, IB4																																																																																																																																									
1) For size, please contact AUMA																																																																																																																																										
2) At max. output torque																																																																																																																																										
3) Conversion factor for output torque to input torque																																																																																																																																										

<b>Service conditions</b>	
Enclosure protection according to EN 60 529	Standard: IP 67 Options: IP 68 (also refer to page 11)
Corrosion protection	Standard: KN Suitable for installation in industrial units, in water or power plants with a low pollutant concentration Options: KS Suitable for installation in occasionally or permanently aggressive atmosphere with a moderate pollutant concentration (e.g. wastewater treatment plants, chemical industry) KX Suitable for installation in extremely aggressive atmosphere with high humidity and high pollutant concentration
Finish coating	Standard: Two-component iron-mica combination
Colour	Standard: Grey (DB 702, similar to RAL 9007) Option: Other colours on request
Ambient temperature	Standard: – 25 °C to + 80 °C Options: – 40 °C to + 60 °C (low temperature), version L – 60 °C to + 60 °C (extreme low temperature), version EL – 0 °C to + 120 °C (high temperature), version H
Lifetime	Open-close duty: Operations (OPEN - CLOSE - OPEN) with 30 turns per stroke GST 10.1: 20,000 operations GST 14.1 – 16.1: 15,000 operations GST 25.1 – 30.1: 10,000 operations GST 35.1 – 40.1: 5,000 operations Modulating duty <sup>4)</sup> : GST 10.1: 5.0 million modulating steps GST 14.1 – 16.1: 3.5 million modulating steps GST 25.1 – 30.1: 2.5 million modulating steps
<b>Accessories</b>	
Limit switching	Limit switching WSH for manually operated valves. For the signalisation of intermediate and end positions (refer to separate data sheet).
Reversing gearboxes	Reversing gearbox GW for reversing the rotation direction for manual and motor operation
<b>Special features for use in potentially explosive atmospheres</b>	
Explosion protection	II2G c IIC T4 in compliance with ATEX 94/9/EC
Type of duty <sup>5)</sup>	During open-close duty: Short-time duty S2 - 15 min. at 50 % of maximum nominal output torque up to GST 14.5 and at 35 % of maximum nominal output torque from GST 16.1  During modulating duty: Intermittent duty S4 - 25 % at maximum modulating torque
Ambient temperature	Standard: – 20 °C to + 40 °C Options: – 40 °C to + 40 °C (low temperature) – 20 °C to + 60 °C – 40 °C to + 60 °C (low temperature) – 60 °C to + 60 °C (extreme low temperature) Combinations with actuators SAExC at ambient temperatures > 40 °C with special sizing.
<b>Further information</b>	
Reference documents	Product description Spur gearboxes GST 10.1 – GST 40.1 Dimension sheet GST 10.1 – GST 40.1 Technical data GST 10.1 – GST 40.1 Technical data SA/SAR Technical data GW Technical data WSH
<p>4) The lifetime for modulating duty depends on the load and the number of starts. A high starting frequency will rarely improve the modulating accuracy. To reach the longest possible maintenance and fault-free operation time, the number of starts per hour chosen should be as low as permissible for the process</p> <p>5) The type of duty must not be exceeded.</p>	

### 3. Transport, storage and packaging

#### 3.1 Transport

- Transport to place of installation in sturdy packing.
- If mounted together with actuator:  
Attach ropes or hooks for the purpose of lifting by hoist only to the gearbox and not to the actuator.

#### 3.2 Storage

- Store in well-ventilated, dry room.
- Protect against floor dampness by storage on a shelf or on a wooden pallet.
- Cover to protect against dust and dirt.
- Apply suitable corrosion protection agent to bare surfaces.

In case gearboxes are to be stored for a long period (more than 6 months), the following points must be observed additionally:

- Prior to storage: Protect bare surfaces, in particular the output drive parts and mounting surface, with long-term corrosion protection agent.
- Check for corrosion approximately every 6 months. If first signs of corrosion show, apply new corrosion protection.

#### 3.3 Packaging

Our products are protected by special packaging for the transport ex works. The packaging consists of environmentally friendly materials which can easily be separated and recycled.

For the disposal of the packaging material, we recommend recycling and collection centres.

We use the following packaging materials:

Wooden material boards (OSB)/cardboard/paper/PE film

### 4. Fitting the handwheel

For gearboxes designed for manual operation, the handwheel is supplied separately. Fitting is done on site according to figure 1.

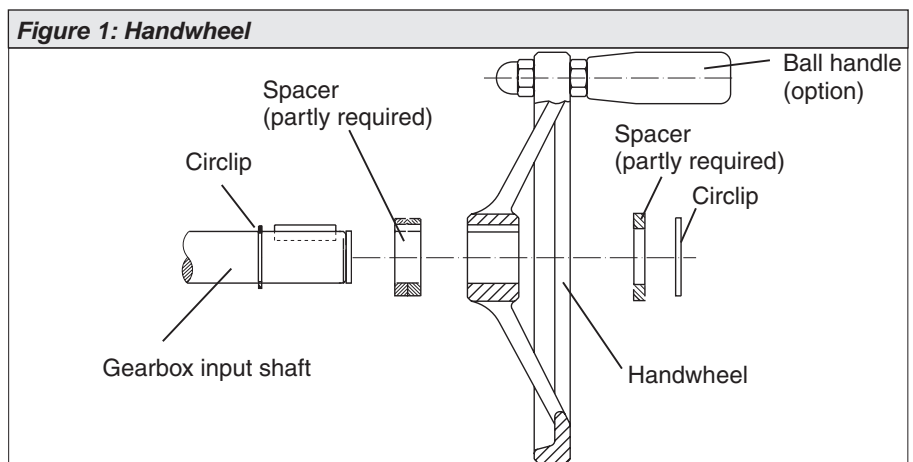

## 5. Mounting multi-turn actuators SA/SAR

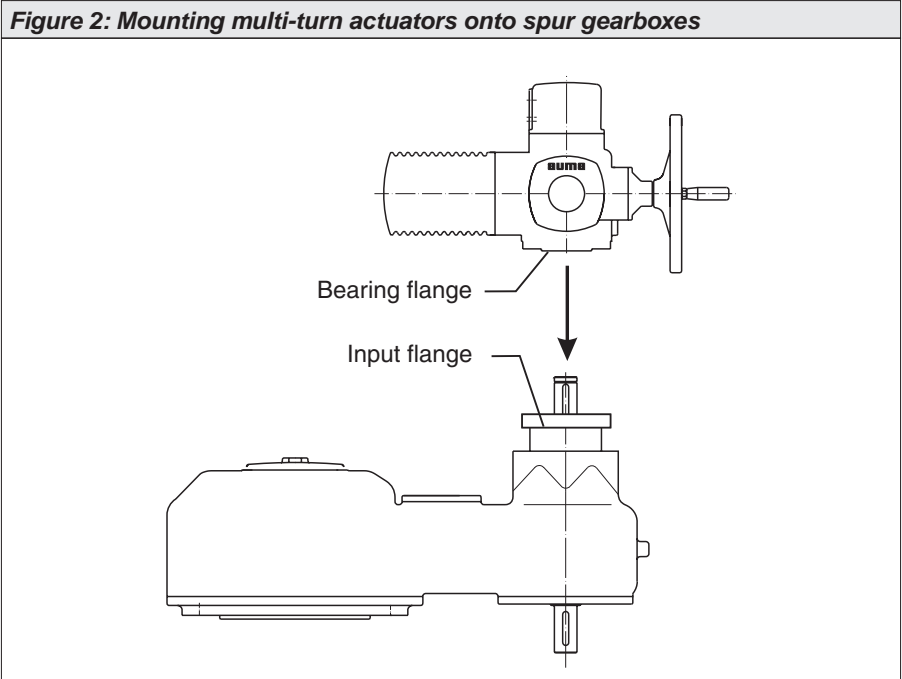

### Mounting the multi-turn actuator:

- Thoroughly degrease the faces of the bearing flange at actuator and of the input flange at spur gearbox.
- Place the multi-turn actuator on the spur gearbox.
- Ensure that the spigot mates uniformly in the recess and that the mounting faces are in complete contact.
- Fasten actuator with bolts and lock washers (see table 1) at the flange of the spur gearbox.
- Fasten bolts crosswise with a torque according to table 2.



**Do not attach ropes or hooks for the purpose of lifting the actuator by hoist to the handwheel. If multi-turn actuator is mounted on gearbox, attach ropes or hooks for the purpose of lifting by hoist to gearbox and not to multi-turn actuator.**

**Table 1: Bolts for mounting AUMA multi-turn actuators on spur gearbox**

Gearbox	SA(R) 07.5-F10/G0			SA(R) 10.1-F10/G0			SA(R) 14.1-F14/G1/2		
	Bolt	Lock washer	Pcs.	Bolt	Lock washer	Pcs.	Bolt	Lock washer	Pcs.
GST 10.1	M 10 x 25	B 10	4	M 10 x 25	B 10	4	M 16 x 40	B 16	4
GST 14.1				M 10 x 25	B 10	4	M 16 x 40	B 16	4
GST 14.5				M 10 x 25	B 10	4	M 16 x 40	B 16	4
GST 16.1							M 16 x 40	B 16	4
GST 25.1							M 16 x 40	B 16	4
Gearbox	SA(R) 14.5-F14/G1/2			SA(R) 16.1-F16/G3			SA(R) 25.1-F25/G4		
	Bolt	Lock washer	Pcs.	Bolt	Lock washer	Pcs.	Bolt	Lock washer	Pcs.
GST 14.5	M 16 x 40	B 16	4						
GST 16.1	M 16 x 40	B 16	4						
GST 25.1	M 16 x 40	B 16	4	M 20 x 50	B 20	4			
GST 30.1	M 16 x 40	B 16	4	M 20 x 50	B 20	4			
GST 35.1	M 16 x 40	B 16	4	M 20 x 50	B 20	4	M 16 x 50	B 16	8
GST 40.1				M 20 x 50	B 20	4	M 16 x 50	B 16	8

## 6. Mounting to valve

The gearboxes can be operated in any mounting position.



- Prior to mounting, the gearbox must be checked for damage. Damaged parts must be replaced by original spare parts.
- After mounting to valve, touch up any possible damage to paint finish.

- Check if mounting flange fits the gearbox.



**Spigot at flanges should be loose fit!**

The output drive types B1, B2, B3, or B4 (figure 3) are delivered with bore and keyway (usually according to ISO 5210).

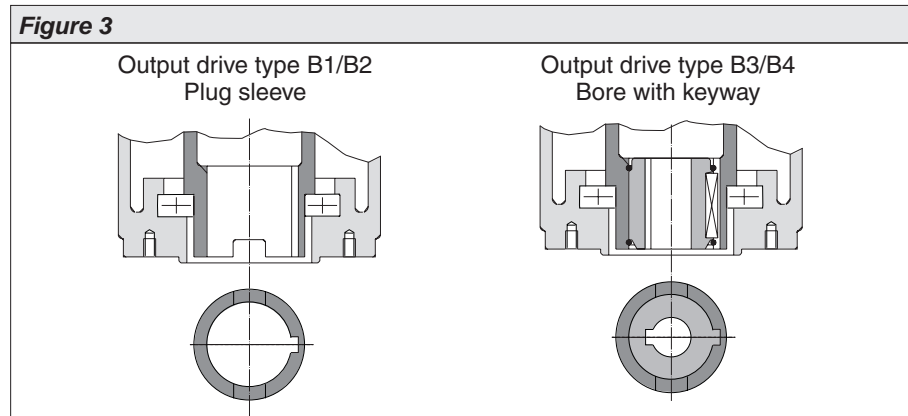

For output drive type A (figure 4), the internal thread of the stem nut must match the thread of the valve stem. If not ordered explicitly with thread, the stem nut is unbored or with pilot bore when delivered. For finish machining of stem nut, refer to next page.

- Check whether bore and keyway match the input shaft of valve.
- Thoroughly degrease mounting faces of gearbox and valve.
- Apply a small quantity of grease to input shaft of valve.
- Place gearbox on valve and fasten. Fasten bolts (quality min. 8.8, refer to table 2) evenly crosswise.

**Table 2: Fastening torques for bolts**

Thread	Fastening torque $T_A$ [Nm]		
	Strength class		
	8.8	A2-70/A4-70	A2-80/A4-80
M 8	25	18	24
M 10	50	36	48
M 12	87	61	82
M 16	214	150	200
M 20	431	294	392
M 30	1 489	564	–
M 36	2 594	–	–

**Finish machining of stem nut (output drive type A):**

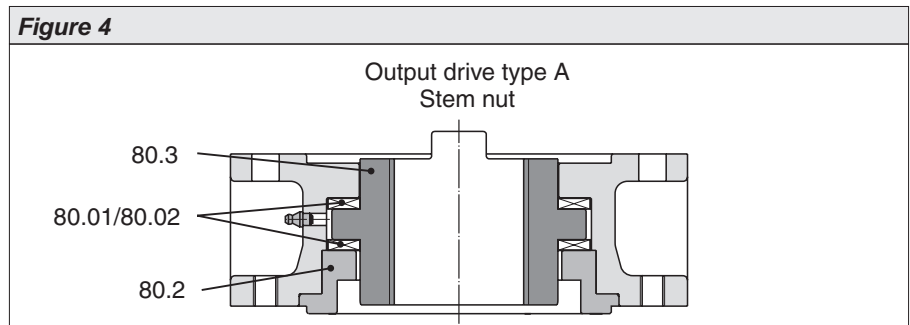

The output drive flange does not have to be removed from the gearbox.

- Remove spigot ring (80.2, figure 4) from mounting flange.
- Take off stem nut (80.3) together with thrust bearing (80.01) and thrust bearing races (80.02).
- Remove thrust bearing and thrust bearing races from stem nut.
- Drill and bore stem nut and cut thread.  
When fixing in the chuck, make sure stem nut runs true!
- Clean the machined stem nut.
- Apply Lithium soap EP multi-purpose grease to thrust bearing and races, then place them on stem nut.
- Re-insert stem nut with thrust bearings into the mounting flange. Ensure that dogs are placed correctly in the slots of the hollow shaft.
- Screw in spigot ring until it is firm against the shoulder.
- Press Lithium soap EP multi-purpose grease on mineral oil base into the grease nipple with a grease gun (for quantities, please refer to table):

Output drive	A 07.2	A 10.2	A 14.2	A 16.2	A 25.2	A 30.2	A 35.2	A 40.2
Qty <sup>1)</sup>	1.5 g	2 g	3 g	5 g	10 g	14 g	20 g	25 g

1) For grease with density  $\rho = 0.9 \text{ kg/dm}^3$

**Protection tube for rising valve stem**

- Seal thread of protection tube with hemp, Teflon tape, or thread sealing material.
- Screw protection tube (1) into thread (figure 5) and tighten it firmly.
- Push down the sealing (2) to the housing.
- Check whether cap (3) is available and without damage.

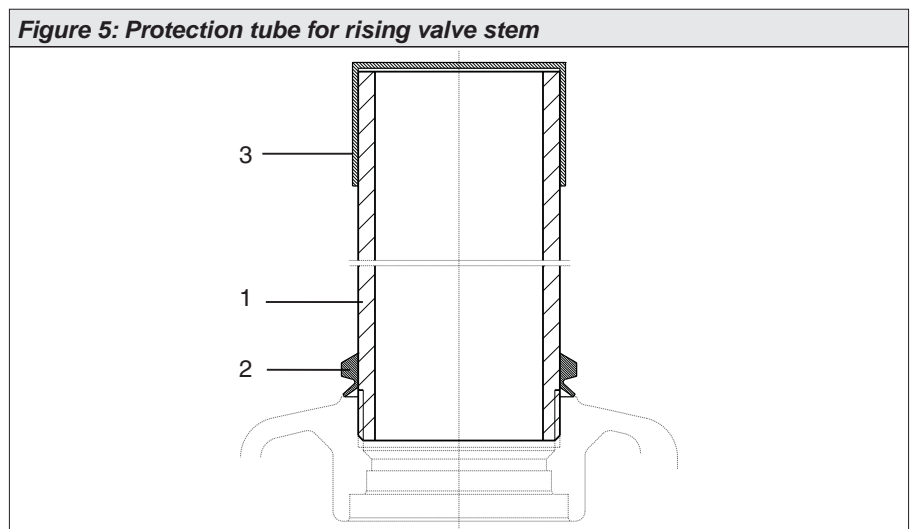

## 7. Operation of valves

The max. output torque (refer to technical data, page 4 or name plate) refers to the peak values and should not be applied over the whole travel.

Clockwise rotation at input shaft results in clockwise rotation at output drive

### For motor operation:

- Observe operation instructions pertaining to multi-turn actuator.
- The setting of the torque switching within the multi-turn actuator may not exceed the max. permissible input torque for both directions (refer to technical data, page 4, or name plate).
- Set the torque switching within the multi-turn actuator to the following value to prevent any damage to the valve:

$$T_{\text{Torque switch}} = \frac{T_{\text{Valve}}}{\text{Factor}}$$

Factor = Conversion factor from output torque to input torque.  
Refer to values in technical data, page 4.

## 8. Enclosure protection IP 68

### Definition

According to EN 60 529, the conditions for meeting the requirements of enclosure protection IP 68 are to be agreed between manufacturer and user.

AUMA gearboxes in enclosure protection IP 68 fulfil the following requirements in compliance with AUMA definitions:

- Head of water max. 6 m.

If submersed in other media, additional measures for corrosion protection may be necessary; please consult AUMA. Submersion in aggressive media, e.g. acids or alkaline solutions, is not permitted.

### Inspection

AUMA gearboxes in enclosure protection IP 68 undergo a routine testing for tightness in the factory.

### After submersion

- Check gearbox.
- In case of ingress of water, dry actuator correctly and check for proper function.

### Notes

- The enclosure protection IP 68 refers to the interior of the gearbox.
- If the gearboxes are likely to be repeatedly submersed, a higher corrosion protection KS or KX is required.
- We strongly recommend to select the higher corrosion protection KS or KX for gearboxes for buried service.
- Use suitable sealing material between valve flange and gearbox.
- Stem protection tubes and telescopic protection tubes should not be used during submersion, instead use a screw plug made of aluminium.
- When using output drive types A and AF (stem nut), it cannot be prevented that during submersion water enters the bore of the hollow shaft along the thread of the valve stem. This leads to corrosion. The water also enters the thrust bearings of output drive type A, causing corrosion and damage of the bearings. The output drive types A and AF should therefore not be used for gearboxes in enclosure protection IP 68.
- For submersion in water, AUMA recommends to use grease suitable for use in drinking water.
- For continuous submersion, the seals should be changed at shorter intervals.

## 9. Maintenance

### 9.1 General references

After commissioning, check gearbox for damage to paint finish. Do a thorough touch-up to prevent corrosion. Original paint in small quantities can be supplied by AUMA.

AUMA gearboxes require only very little maintenance. To ensure that the gearbox is always ready to operate, we recommend – provided that on an average not more than 10 operations are performed per year – the following measures:

- Approximately six months after commissioning and then every year check bolts between multi-turn actuator, gearbox, and valve for tightness. If required, tighten applying the torques given in table 2 (page 8).
- Perform a test run as well as a visual inspection for grease leakage every six months.
- Carry out a detailed functional test for each gearbox every 5 years. Record the results for future reference.
- For gearboxes permanently exposed to ambient temperatures above 40 °C, maintenance must be performed at shorter intervals.
- For gearboxes with output drive type A: at intervals of approx. six months from commissioning, press in Lithium soap EP multi-purpose grease on mineral oil base at the grease nipple with grease gun (for quantity, refer to table 3, page 9).

#### Seals:

The seals must be changed when changing the grease. Seal kits may be obtained from AUMA.

#### Grease:

A grease and seal change is recommended after the following operation times:

- if operated seldom, after 10 – 12 years
- if operated frequently, after 6 – 8 years



- **Only original AUMA grease must be used.**
- **For the grease type, refer to the name plate: Standard F1**
- **Lubricants should not be mixed.**

**Table 4: Grease quantities for spur gearboxes**

GST		10.1	14.1	14.5	16.1	25.1	30.1	35.1	40.1
Qty	dm <sup>3</sup>	0.8	1.54	1.54	3.1	6.3	12.1	22.0	22.2
Weight <sup>1)</sup>	kg	0.7	1.4	1.4	2.8	5.7	11.0	20.0	20.2

1) for  $\rho = \text{approx. } 0.9 \text{ kg/dm}^3$



**The removed lubricant and the cleaning agent used must be disposed of according to the relevant regulations.**



**For safe operation of explosion-proof products, the gear housing has to be lubricated in compliance with the manufacturer specifications. In the event of lubricant loss, repair measures have to be initiated without delay.**























